

The Nova/Sterling/Eureka Kit Car

*(A.K.A. The Sebring, Cimbria, Sovran, Puma, Totem, Eagle, Scorpion,
Ledl, Defi, Gryff and Tarantula)*

This copyright free edition may be freely distributed and passed on.
Printed versions are available to buy from lulu.com

<https://www.lulu.com/shop/search.ep?keyWords=nova+kit+car&type=>

First Published Date March 2007





Cover Photograph by I.R.L Sutherland

Preface

I don't think a work like this is ever complete.

The more I researched this book the more I realised I didn't know. For that reason I apologise for any omissions and errors that are unknowingly contained within. I welcome any criticisms or factual corrections the reader may wish to inform me of.

Should you wish to advise me of any thing you think should go into future editions of this book please write to me.

email – Newstarbooks@aol.com

Phill Fenton – March 2007

Contents

Introduction

Part One

Chapter 1/ History of the Nova	Page 9
Chapter 2/ Nova Derivatives	Page 23
Chapter 3/ Nova Stories	Page 42

Part Two **Diary of a build up**

Chapter 4/ The Floor pan	Page 50
Chapter 5/ The Kit Arrives	Page 65
Chapter 6/ First Drives	Page 79
Chapter 7/ Finishing and final registration	Page 84
Chapter 8/ Disaster Strikes!	Page 89

Appendices

Interviews

Richard Oakes (The designer of the Nova)
Sam Cobley (Nova Manufacturer from 1993-1996)
Mike McBride (Sterling Manufacturer from 1995–2006)

Introduction

Around about 1970 when I was 13 years old I visited the Kelvin Hall in Glasgow to see a car exhibition called “The Jackie Stewart speed show”. For me the highlight of the day was seeing a fabulous futuristic car called the “Probe 2001”. What astonished me though was that this car was being offered for sale at a price little more than what my father had paid for the brand new white VW Beetle he owned.



The Dennis Adams designed – “ Probe 2001 ”

The “2001” was only 37” in height and featured an electrical roof assembly that slid forward to allow the occupants to get in and out. The car was a development of an earlier design called the Probe 16. This was even lower than the Probe 2001 with a height of only 34 inches. Entry was also gained by climbing in over the roof .

The Probe 16 went on to be featured in the film “A Clockwork Orange” directed by Stanley Kubrick and starring Malcolm Mcdowell.

Only 3 Probe 16s were ever produced. 2 have been destroyed and the only remaining car is owned by Phillip Karam in Ottawa Canada.

The Probe 2001 was to be sold as a kit car based on BMC running gear. The car featured a mid engined transverse mounted 1800 BMC engine. Sixteen Body shells of the Probe 2001 were produced between 1970 and 1972 (Four by Dennis Adams himself, and a further twelve by a company based in Irvine (Scotland) called The Caledonian Probe Motor company.

In retrospect, I believe that the Probe was the precursor that sparked my passion for this type of car and led me to eventually build my own Nova which is described later in this book.

I also suspected that the Probe may have influenced the Novas design (though this has never been acknowledged in any of the magazine articles and literature I have read about it's design history). The unique scalloped wheel arches and opening roof are common features of both cars. Consequently, during my research for this book, when I spoke to Richard Oakes (who designed the Nova) I asked if this car had influenced him. He mulled this over for a few seconds and replied that he had been aware of the "Probe" design exercises (indeed he knew Dennis Adams) and although he had not been conscious of this at the time, perhaps the Probe did indeed have a subliminal effect on his design.

Later descendants of the Probe (called the Pulsar and the Centaur) went on to be sold as kit cars in the early seventies, but to me these variants were never as beautiful as either the Probes or the Nova.

I sold my car in 1986 but still have fond memories of it. In recent years my interest has been re-kindled from looking at websites created by enthusiasts of the marque. However, after searching for a book about the car I was disappointed to discover that as of 2006 it would appear none had ever been written. I therefore resolved to do all the research necessary to write my own book. This would also provide an outlet for a detailed diary and set of photographs I had kept from the time when I built my own car back in 1983/4

What follows is the result:-



The Nova Kit Car that I built in 1983/4

Chapter 1

The History of the Nova

The Nova was the brainchild of Richard Oakes a talented individual who began his working life in 1962 as an apprentice sign writer.

In 1968 he joined the Davrian car company where he first saw the potential for a well designed and engineered Kit Car. He left Davrian about a year later and went to work at Western Laminates (an industrial glassfibre company) based in Brixham, Devon. During his time there he managed to persuade his employers to allow him to create a fibreglass vehicle body to fit on a VW floor pan and by 1970 he had produced his first design - the Tramp Beach Buggy. Richard created the car purely for himself, and gave the moulds to his employers to put the Tramp into production. Over 75 were made in its 18 month production life.



The Tramp Beach Buggy

Richard then went on to design the Nova, another VW based car. This was to be no ordinary Beach Buggy but a futuristic design with styling features only available on the “Super Cars” of the day. Richard realised there was a market for an affordable car that exploited a person’s ego. The Lamborghini Miura and the Ford GT40 were big influences in the Novas design. The height of the car was deliberately targeted to be close to the GT40s famed 40 inch height (the original

Nova ended up being 42 inches tall). The Mako Shark 2 show car of 1965 (a design exercise to demonstrate future possibilities on production Chevrolet Corvettes) was another strong influence.

Richard believed these three cars had conditioned people to expect these influences in future car styling and he took what he felt were the best features from each design and added to them to create the Nova. Amongst other styling cues, the cars rear louvre panel was directly inspired by the Miura. The air intakes on the bonnet were a feature copied from the GT40 whereas the air intakes on the sides of the Nova were features copied from both the Miura and GT40. The Mako Shark is strikingly similar in profile even though this was a front engine car as opposed to the Novas rear engine layout. However, apart from the exotic design, what made the car really stand out from anything else available was the sensational opening canopy. This went one step further than extravagant gull wing doors... the entire roof section lifted up instead! This feature had rarely been seen in any car apart from the Testudo, a design exercise by Bertone in the mid 60s that featured a forward hinging opening canopy.



BERTONE 

The Bertone Testudo. This car was based on the American Corvair which also features a rear mounted air cooled Boxer engine (as per Beetle). Was this also inspiration for the Nova? (Picture reproduced by kind permission of Bertone)

The Bond bug, (a three wheeler car aimed at the youth market) also featured a forward hinging opening canopy. The Bond bug was launched in 1970.

Richard told me that when he designed the Nova it had been designed for the enjoyment of the person looking at the car and not for the driver. Subsequently, in complete contrast to this, the cars he went on to design in later years were deliberately designed for the drivers benefit with the visual appeal of the car becoming of secondary importance.

Before Richard left Davrian in 1969 he had persuaded his boss to give his job to his friend Phil Sayers (a buddy since they were teenagers). Later, Phil was persuaded to quit Davrian to team up with Richard in his ambition to put his ideas for the Nova into production. Together they obtained financial backing from John Willment who ran a company called JW Automotive (amongst other things this company built GT40s for the Ford motor company). John Willment also owned a shipyard and provided workshop facilities for Richard and Phil in Woolston, Southampton. Thus the company “Automotive Design and Development Ltd.” was born.

It took about a year to produce all the patterns and moulds for the car (very quick by to-days standards). The first prototype Nova styled by Richard and engineered by Phil was completed in December 1971, and a production kit was announced early in 1972 selling for £750. Success came very quickly. “Motor” magazine even described the Nova as “the most Beautiful Car in the world”.

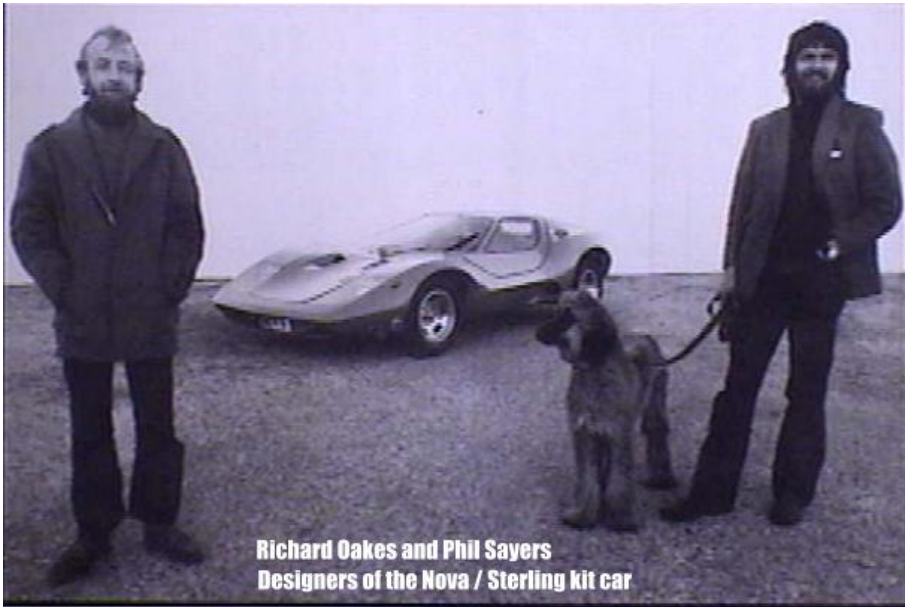

**Richard Oakes and Phil Sayers
Designers of the Nova / Sterling kit car**

Richard is on the left, Phil is on the right.

The two man company went into the black within a few months of the Nova going on sale. Originally Richard and Phil had anticipated sufficient demand to warrant producing one car a week. However, following two major British car magazine stories and a low key advertising campaign demand was such that they soon had to double this to two cars a week. Even then they still had a 17 week waiting list for the car with customers even offering bribes to get themselves to the front of the queue.

The company quickly outgrew their premises in Southampton, and spurred on by Phil's desire to move to the North of England the company decided to re-locate their manufacturing base to Acrinton, Lancashire in late December 1973.

Around about this time the world's oil crisis started to have an effect on the British economy. Added to this was the introduction of VAT (introduced in the UK in April 1973), rampant inflation and an unsure future meant that even though the car remained highly desired by many, orders were being cancelled and Phil Sayers left the company. Richard Oakes and his wife Annie determined to keep the company going by downsizing the business, subcontracting the fibreglass lamination work and moving to smaller premises in Earby, Lancashire.

However, despite their efforts, by September 1975 it was all over and Automotive Design and Development Ltd. went into Liquidation.

Altogether about 179 cars had been sold and Richard Oakes subsequently sold the moulds and the rights for the design for £5,000 to a gentleman called Neil Mcmanus (A.K.A. Noel Redding). who despite his good intentions never quite managed to bring the Nova back to the market on his own.

Over the next three years, the public interest in the marque remained buoyant fuelled by regular press releases and articles about the car. Finally in 1978 Vic Elam (a successful business man who had made his money in the bulk liquid haulage business) took over and re-launched the car from premises in Queensbury West Yorkshire. The new company called Nova Cars was soon thriving. So much so that they were forced to move again to larger premises in Dewsbury, West Yorkshire.

The first kits sold were based on the original jigs and moulds from Automotive Design and Developments (these cars later became known as the series one Nova). A basic kit consisting of all the fibre glass body mouldings as well as windscreen, hinges etc. was offered at £1250.





This series of photographs show the fiberglass components making up the basic kit

A deluxe kit which also included trombone exhaust systems, seats, wheels, tyres and instruments sold for £1850.



Photographs reproduced with kind permission of the Triford Motor Company, Huddersfield, England

During this time two other versions of the Nova went on sale. The more ambitious of the two was Crestwick Ltd. a company run by Steve Driver. Steve had first owned a Nova in 1974 and many examples had passed through his hands providing him with a lot of experience with the cars. He planned to offer kits in primer finish complete with sun roofs for £1800 plus tax. Large adverts appeared in magazines and colour brochures were printed. Demo cars were also prepared (one with a twin cam Lotus engine) and the car was to be called the Nova SSD (the “SSD” stood for second series design). The moulds for this car were taken from existing body panels rather than from a properly prepared body plug. Workshop facilities were in Staines Middlesex and all fiberglass work was to be sub contracted.

The second challenger was run by Don Law of Swindon, a sincere Nova enthusiast who had owned various examples of the car in his time. He was to act as a retail outlet for a very shy partner who claimed to own another set of moulds based on an early Southampton car. This operation planned to sell a set of body panels in primer finish for £620.

These two manufacturers struggled to source windscreens for the kits they were supplying and soon disappeared from the market place when up against the much slicker “Official” Nova Cars run by Vic Elam.

By 1981 a new version was launched by the Elam owned company called the Nova series two. This car featured a higher roof line which increased the occupants head space by 2 inches. The distinctive air intakes of the original Nova were also absent from the front bonnet section and the front under tray panel. The back of the car now featured a separate Bumper moulding and a re-designed rear panel. Inside the car, the dashboard was updated with a single dash layout instead of the earlier two pod design.

The Nova also featured in films which came out in the early 1980s. In 1981 “Condorman” was made. This was a Disney film starring Michael Crawford as the super Hero. Modified versions of the Nova were used in the film.

Another Nova (an American derivative called the Sovran) could be seen in the film “Cannonball 2”, and the Nova also featured (albeit very briefly) in “Death race 2000 which was released in 1975”.

It is also rumoured that in the 1970s a Nova also featured in a live action film produced by Gerry and Sylvia Anderson (famous for the Thunderbirds TV series). My research has discovered that Gerry and Sylvia Anderson produced a number of different hour long pilot TV shows. None of which have ever been broadcast. The Nova may well have featured in one of these pilot programs.

In 1983 the company had moved again to new premises in Mirfield, West Yorkshire. By now the company had changed its name to Nova Sports Cars, and Craig and Carl Elam had also joined the business. Sales peaked at around twelve cars per month.



Bridge Garage, Mirfield, West Yorkshire

I visited the company for the first time in March 1983 when I was shown around the entire operation and was given a test drive in a Nova demonstrator.



A Nova demonstrator on display in the showroom at Bridge Garage.

Production of the VW Beetle saloon had ceased in Germany on the 19th January 1978 (Although the Cabriolet version continued to be manufactured in Germany until the 10th January 1980). Consequently, I could foresee a time when donor vehicles would be in short supply. I recall asking Carl Elam what they would do when there were no longer any donor vehicles available for people to build their Novas. "We'll

start selling replica Beetle body shells for people to convert Novas back again” he replied.



A complete kit awaiting delivery. This was a deluxe kit supplied complete with reconditioned floor pan assembly

Joking aside, the company was already looking towards the future and had even been involved in the development of a prototype chassis based on Triumph Herald running gear (this chassis was called the AVC which stood for Alternative Volkswagen Chassis).

Another interesting development around about this time was the introduction of the “Bermuda” Top Nova. This was a re-designed roof section featuring a removable and storable rigid hard top, opening windows and a quarter side light. The Bermuda top sold for £380 plus VAT and could be fitted to existing cars



The Bermuda top version of the Nova

The kit car industry was booming in the mid eighties and competition was very tough. Competitors started introducing their own “Exotic cars” with amongst others, replica kits based on the Lamborghini Countach and AC Cobra becoming available. These kits were designed around more modern running gear featuring bigger more powerful engines and purpose built chassis. Inevitably this affected sales of the Nova and gradually interest in the car began to wane. Nova sports cars Limited was dissolved in April 1988 and ownership of the Nova rights transferred to TFS Ltd. which continued to be run by the Elam family.

One highlight in 1988 was the announcement that the company had secured a contract with Pinewood Studios in England to supply a lifting canopy section for the forthcoming Batman movie.

In January 1989 it was announced that the ownership of the rights to the Nova had been transferred to a new company registered as Elams of Mirfield.

On the 5th September 1989 the Nova rights were sold to Graham Slayford of Leigh on Sea, Essex, who started a new company called Nova Kit Cars Ltd.

Initially things started well with the company planning to build up a stock of parts and panels before launching properly in April 1990 at the National Kit car show. However, they were soon experiencing their own problems when Transplas Ltd. (a sub contract company who

produced the fibreglass panels) folded. It took months of legal wrangling to prove that the moulds actually belonged to Nova Kit Cars and not Transplas. Eventually by May 1991 the moulds had been returned and Nova Kit Cars Ltd. were back in production. They even introduced a new Dash and Under tray moulding. However, by March 1992 Nova Kit Cars were themselves forced to cease trading. A search of companies house register confirms that the company was dissolved in 1992. At this point in time Nova kit cars were subcontracting the laminating work to another company called “Vanguard Mouldings” who were given ownership of the moulds by the official receivers of Nova Kit cars in lieu of payment for work already carried out.

Not long after Nova Kit Cars ceased trading, Sam Cobley (another Nova enthusiast) found himself needing a new dashboard panel for his own car. He contacted the official receivers and was told the moulds now belonged to the subcontract company that had been supplying Nova Kit Cars. He visited the company in Southend-On-Sea in the hope of persuading them to produce a dashboard moulding for his car. The company weren’t interested in producing a “one off” and explained that they had been given ownership of the moulds as a consequence of not having been paid for the work they provided to Nova Kit Cars. They explained they were looking to sell the Moulds for £5000. Sam jokingly offered to pay them £1500 in cash and was stunned to have his offer accepted.

Being unsure about the “rights and title” of the Nova Sam checked with the official receivers to be told “you cannot legally sell an item if it is not fit for the purpose for which it is being sold”. When the receivers gave the subcontractors the moulds, the “rights and title” went with them. Consequently, when the moulds were sold onto Sam Cobley he automatically gained the “rights and title” as a result.

And so it was that in 1993 Sam Cobley and his wife Lynne formed a new company called Nova Developments Ltd. based in Newquay, Cornwall. At that time around about 1,000 Novas already existed in Britain which meant there was a ready a market for spare body panels to ensure a viable business.



*Sam Cobley
Standing next
to his new
improved
Nova*

Initially Sam had not intended to put the Nova back into production. His original intention was to supply spare parts only. However, soon he was being asked to supply a complete kit and once the word was out magazines became interested in his plans for the car. Consequently the Nova was put back on the market as a complete kit.

The Cobleys improved the car with new moulds for the front bonnet, front undertray and the side sills. The moulds that he'd bought included the original series one roof moulding. This was modified to produce a new roof section that was two inches higher and featured a less raked windscreen which also placed the screen two inches further away from the drivers head. Steel frames were introduced for the side windows to allow these to be hinged and removable to improve ventilation into the cockpit of the car. At the back a new rear panel was produced that utilised Vauxhall Cavalier tail lights fitted upside down. The rear louvre panel was discontinued and a neat lip spoiler was fitted above the rear window. The engine cover was also updated. Pop up headlights were offered as an option, whilst a new dashboard was designed for inside the car. A mid engine chassis based on Mk3 Escort running gear was designed and two were sold at the Stoneleigh show even though the enquirers were advised that they weren't really ready and required further development. The customers were so desperate to buy them they took them anyway.

After three years in production the work took its toll and Sams marriage broke up. His wife (who had been a co-director) asked that

the company be dissolved and as a result Cobley Engineering was set up to continue production of the car.

After about a further 18 months with new legislation due to come into effect (SVA testing) Sam decided it was going to cost too much money to get the car to comply so he decided to sell the business.

In the time that Sam ran his two companies he produced a total of 15 full kits.

Since 1997 the marque has been owned by Shashi Dvyas and partner Martin Brown calling themselves Aerotec Nova.



In 1999 Shashi Dvyas announced plans to withdraw completely from the Kit Car market and concentrate on developing a version of the Nova designed for racing. Since then nothing more has been heard.

It would appear that these days there is no longer sufficient demand for this car for any company to remain commercially viable supplying Nova body kits. The VW Beetle is now a 70 year old design and is no longer in production. Not only is the running gear out of date – but the source of donor vehicles is also drying up!

Perhaps now is the time for someone to launch a new company producing replica fibreglass Beetle body kits to allow Nova owners to convert their cars back into VW Beetles just as Carl Elam suggested to me all those years ago ;)

Time Line (United Kingdom)

- 1971 – Nova Prototype Development (Richard Oakes/Phil Sayer)
- 1972 – Nova introduced by Automotive Design and Development.
- 1973 – UK introduces VAT, ADD moves to Ayrington
- 1974 – Oil crisis knocks consumer confidence
- 1975 – Nova Ceases Production
- 1976
- 1977
- 1978 – Nova re-launched by Nova Cars (Vic Elam)
- 1979
- 1980
- 1981 – Nova Series 2 Introduced
- 1982
- 1983 – Nova Cars re-named Nova Sports Cars
- 1984
- 1985
- 1986
- 1987
- 1988 – Nova Sports cars re-named TFS Ltd.
- 1989 – TFS Ltd. re-named Elams of Mirfield
- 1990 – Company sold to Graham Slayford who launches Nova Cars
- 1991
- 1992 – Nova cars liquidated
- 1993 – Sam Cobley launches Nova Kit Cars
- 1994
- 1995
- 1996 – Nova Kit cars become Cobley Engineering
- 1997 – Moulds sold to Aerotec Nova
- 1998 until 2007 – Nova out of production

Chapter 2

The Nova Derivatives

With the success of the Nova in Britain, an American company called California Component Cars (run by Norman Rose and Cecil Robertson) soon acquired the rights to supply the car in California and six surrounding states.

Norman and Cecil had already run a successful car repair shop but were becoming bored and looked around for something else to inspire them. The Nova fitted the bill, and Norman and Cecil wrote to Automotive Design and Developments in Britain in a vain effort to obtain a license to produce the car in America. Richard and Phil just didn't have the time or the inclination to expand the business in to the USA so ignored these early letters. Eventually Norman and Cecil flew to Britain in an attempt to track down Richard and Phil and finally persuaded them to sell the rights to produce the car under license in California

The Chevrolet Nova was already a registered name so the American version of the car had to be re-named the **Sterling**.

In the early 1970s a complete Nova was purchased and brought to the USA in a 747 Cargo Jet. This was disassembled and used to produce a set of Moulds for the Sterling production model. This car was almost identical to the Nova being sold in Britain at that time. Richard Oakes and Phil Sayers spent a couple of weeks in California to provide technical assistance to help the American company to set up production of the car. The car was launched in the US in 1973.

Minor differences included a different canopy vent treatment to the Nova. Early Sterlings also had a slightly warped top near the front on the passenger side.

Later in 1976, the company expanded to cover the whole of the States after buying a further licence from the Liquidators of Automotive design and developments Ltd.

The original Sterling had a production run of about 765 total bodies.



A fine example of the Sterling – This is the same as the series one Nova as can be seen by the air intakes on the front bonnet and under tray. (Photos Courtesy of owner Steve Silverstein)

In 1980 a competitor to the Sterling sprung up in the USA. This car was called the **Sebring**. Al Hildenbrand an ex Sterling distributor took the car to Bremen Manufacturing in Indiana to manufacture the new model. The Sebring is thought to have been developed by taking a set of moulds from a Sterling and modifying these with a higher roofline and (later) lower beltline along with a different nose section and rear lights. Both the Sterling and Sebring shared the same windscreen so the overall proportions of the canopy were the same for each car. Later models of the Sebring had a full fibreglass floor to produce a more rigid body structure. Production of the Sebring ran until the late 1980s and it has been claimed that in total about 1500 were produced. My personal view is that this is probably an exaggerated figure when you consider that the original Sterling claimed a production run of 765 bodies



Sebring – Note the higher roof line – smoothed out sides and different front bonnet. The roof canopy also cuts deeper into the main body tub (Photo courtesy of owner Paul Hawkins)

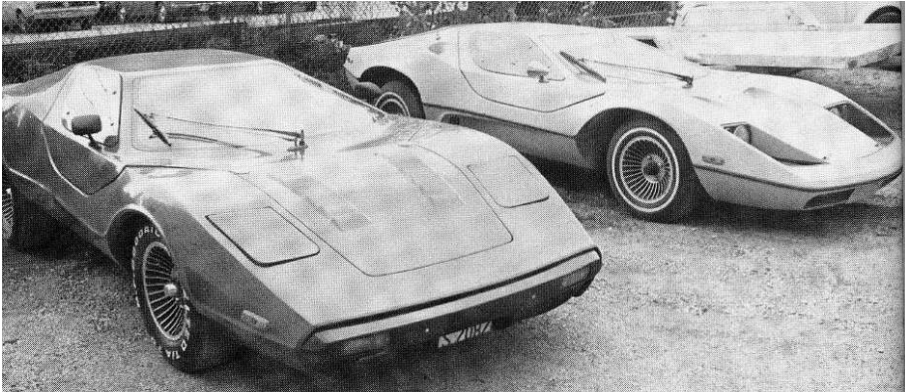

On the left is an early version of the Sebring next to an original Sterling – Note that this Sebring has a canopy more closely resembling the Sterling canopy than on the previous example.

Introduced in 1978, the **Cimbria** was another re-designed version of the original Nova. This was produced by Amore cars, a company headed by Joe Palumbo. The Cimbria did away with the opening canopy section, and featured gull wing doors instead.

The moulds for the original car are rumoured to have been taken from an early Sebring and subsequently modified. The Cimbria also featured the one piece body with integrated fibreglass floor pan as seen on the Sebring which also adds weight to this rumour. However, the Cimbria was launched in 1978 two years before the Sebring actually went on sale? Thus I am inclined to believe that the Sebring was actually a copy of the Cimbria which reverted back to the lifting roof assembly of the Nova/Sterling. I would be pleased to hear from anyone who could verify the true chain of events.



Side view of the Cimbria – Note the differences between this car and the Sterling, but the many similarities to the Sebring. (Photo courtesy of owner Farzad Sharif)

In addition to Gull wing doors, the Cimbria also featured a modified nose section and bumper panel, smoothed out side pods (minus air intakes) and air intakes moved from behind the window to just above the cars waistline amongst other details.

Production of the Cimbria ran from 1978 until about 1982 during which time about 500 were made.

In 1991 Neria Yachts in Wilmington, North Carolina bought the Cimbria moulds and a number of cars (at least 10) have since been produced. Neria were thought to have folded in the late 90s and the moulds scrapped, but an internet search in 2006 reveals a car looking like an improved version of the Cimbria called the Neria, is still being marketed. Whether or not the company is truly active is open to question.

The Cimbria SS was to return to Britain in 1981 re-named the Eagle SS when Tim Dutton Wooley (owner of the Dutton Kit car company)

and his cousin Alan Breeze purchased the rights to replicate the Cimbria and re-named this version of the car the Eagle SS (by coincidence the South African version of the Nova was also called the Eagle). Alan Breeze became the head of the new “Eagle Cars” and the company paid a one off flat fee to reproduce the Cimbria in Britain and the EU. This fee also provided him with a complete Cimbria car from which he was able to produce a new set of moulds. Development of the new Eagle was aided by its close association with the already well established Dutton Car company. The British version of the Cimbria was modified with Porsche 928 style pop up headlamps and was initially offered as a Beetle based kit but soon afterwards a Ford Cortina front engined version was developed which used its own purpose built chassis. Later still a 2+2 version was designed and put into production. By now the car had evolved to the point that it was virtually unrecognisable as a Nova derivative. Eagle SS production ceased in 1998



The Eagle SS – This is a Cortina based version as can be seen by the central hump on the front bonnet. The rear engined Beetle based kit looked very similar but without the pronounced bonnet bulge required by the Ford based car.

Meanwhile, in 1978, ownership of “California Component Cars” changed hands and an updated version of the Sterling was launched in 1980. The new car was called the **Sovran** (A yellow version of this car featured in the film “Cannonball 2”). The **Sovran** featured squared off wheel arches and air scoops instead of vents behind the windows. The car also featured Mustang rear light clusters.



(Photos - Courtesy of owner Greg Hampton)



Sovran – Note the squared off wheel arches and changes to the front of the car

The Sovran was produced in San Leandro for a very brief period before the company folded. Less than 25 cars were produced. In 1983 the new owner of Californai Component Cars switched locations to San Jose and re-named the car the Sovran GT. In total only about 10 GT bodies were produced. In 1985 the Sovran was discontinued and the Sterling was re-introduced which reverted back to the rounded wheel arches but retained the other new features that were introduced with the Sovran. This version was called the Sterling GT and it is thought that less than 50 were produced

In 1992 ownership of the Sterling was transferred to a company called Redhead Roadsters. This was run as a part time business. It is not known if any actual kits were produced but a rudimentary “Open Top” roof panel was tried out. However, this was not a fully developed double skinned moulding and with the lack of proper rain channels was prone to leaking.

The next owner of the Sterling was Mike McBride. His company (Solid Sterling) bought the Moulds from Redhead Roadsters in December 1995. Mike produced spares and complete kits until 2005. He finally completed the last turnkey Sterling in July 2006.

Throughout this time Mike completed three complete “Turnkey” cars and supplied 4 complete kits as well as a vast array of spare parts for existing Sterling owners. Developments included a double skinned open top roof panel which featured a carbon fibre reinforced windscreen surround and proper rain channels and drainage. Other improvements were a redesigned engine cover and a new rear panel that allowed a bigger choice of rear lights to be used.

Mike only ever ran his company on a part time basis and at the time when I first made contact with him (August 2006) he informed me he had decided to no longer produce full kits or “Turnkey” cars in order to allow him self to spend time on other projects.

In November 2006 it was announced that a new company called Sterling Sports Cars run by David Aliberti was to take over.



In December production was transferred to Pennsylvania (home of the new company) and plans were made to produce the new Sterling RX prototype in time for the 2007 Carlisle Kit/Replicar and import show in the US.

In February 2007, full body kits and spare parts prices were announced with a basic kit offered for sale at \$8650, and a deluxe kit at \$10450. Full details can be found on the companies website:-
www.sterlingsportscars.com

The basic kit comes complete with the Mike Mcbride designed Targa Top which is also offered as a bolt on replacement for existing Sterling owners to retro-fit to their cars.

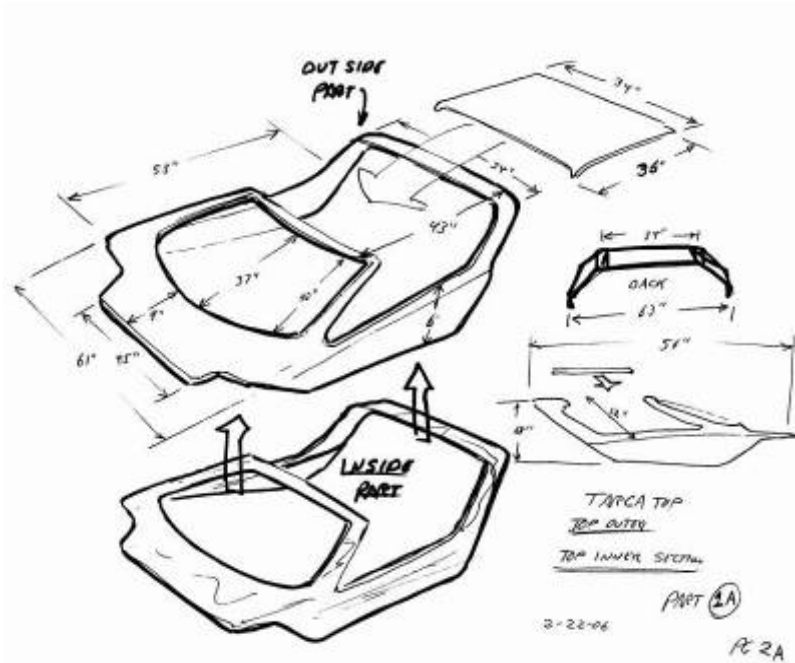

Amongst the companies plans for the future are plans for a mid engine tubular chassis to replace the traditional VW floorpan

Sterling Race Edition

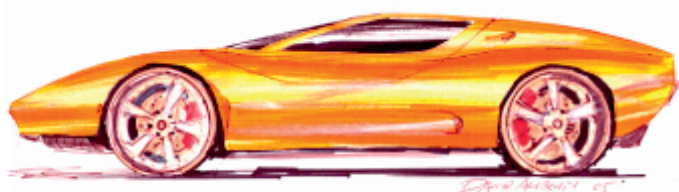
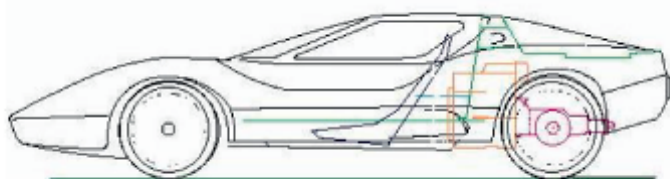
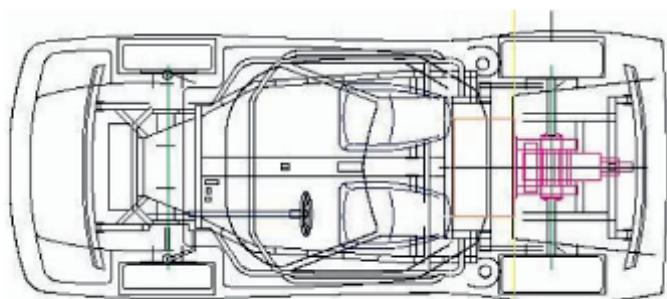

David Aliberti Copyright Protected 10-2005

Time Line (United States of America)

- 1973 – Sterling Launched by California Component Cars
- 1974
- 1975 – Nova Ceases Production in the UK
- 1976 – California Component Cars purchase more rights
- 1977
- 1978 – Cimbria SS produced by Amore Cars
 - California Component Cars sold to new owners
- 1979
- 1980 – Sterling becomes Sovran and Sebring is launched
- 1981 – Cimbria sold under license in UK as Eagle SS
- 1982 – Cimbria Production ceases in USA
- 1983 – California Component Cars sold again to new owners
- 1984
- 1985 – Sovran discontinued, Sterling GT Introduced
- 1986
- 1987
- 1988
- 1989 - Sebring Production Halted
- 1990
- 1991 – Cimbria re-launched as Neria
- 1992 – Sterling now owned by Redhead Roadsters
- 1993
- 1994
- 1995 – Mike McBride launches Solid Sterling in Dec. 1995
- 2006 – Solid Sterling ceases production
- 2007 – Sterling Sports Cars take over production

The Eureka

In Australia the Nova was introduced by Allan Purvis, who had been on holiday in the UK in 1971. He negotiated a deal to produce the car in Australia and New Zealand where he re-named it the Eureka. In total the Purvis car company sold 683 examples of the Eureka in 15 years from 1974 until Allan sold his company in 1989. The first models made in 1974 were almost identical to the series one Nova sold in the UK.



A selection of Eureka's at a car show in Australia

In 1976 a revised model was introduced called the Eureka PL30. This model had a more upright windscreen that was shortened by 2 inches allowing an extra 2.5 inches of headroom for the occupants. A new bonnet was added that no longer had the distinctive “nostril” air intakes. Inside the car the dashboard and centre console were re-designed, while at the back of the car larger tail lights were fitted along with a revised rear lower panel and narrow bumper. The PL30 also introduced the electro-hydraulic opening roof mechanism.

From 1977 until 1991 the Eureka PL30/F4 was produced. The “F4” designation was introduced because a number of models were being made with Ford 4 cylinder 1600cc engines instead of air cooled VW Beetle boxer engines. These cars had a flat rear panel and round headlamps. The roof fit was also improved with the addition of a groove around the body where the canopy fits which also reduced road noise.



Eureka Canopy showing the groove around the body which is unique to the Eureka

A further 1.5 inches of headroom were also achieved with the revised car. Other options available were “Countach” style air intakes and a rear spoiler. The PL30/F4 model also featured the option of an open top roof panel which came to be referred to as the Targa top even though the factory built version never actually featured a true “T” top.



Later still, the company's new owner Colleen Long re-named The PL30/F4 the Eureka XCL. She also produced the FM (Freedom Machine) version of the car. This model did away with the lifting roof canopy and instead had a fixed screen with 2 small side windows. The rear of the car had cut down bodywork which made it into an open top. However, it is not believed that this car ever made it into production.



Another option made available was a Eureka with a “summer screen” instead of the all enclosing roof canopy. This car replaced the canopy with a front screen and small side windows but did not feature the cut down rear bodywork of the FM. The “Summer Screen” could be retro-fitted to any Eureka in place of the opening roof canopy.

The final owner of the company was Paul Nelson. However, legislation in Australia has made it impossible for the Eureka to continue in production.

Time Line (Australia)

1971 – Purvis Cars Launches Eureka Sports

1974

1975 – Nova Ceases Production in UK

1976 - Eureka PL30 introduced

1977 – PL30/F4 Introduced

1978

1979

1980

1981

1982

1983

1984

1985

1986

1987 – “Unofficial” Eureka sold in New Zealand

1988

1989 – Eureka sold to Colleen Long – PL30/F4 renamed XCL

1990

1991

1992

1993

1994

1995

1996

1997

1998

1999

2000

2001

2002 – Paul Nelson moves the factory to Dandenong Victoria where
Production halted

In Italy the Nova was developed and sold as the Puma and the Totem.



Puma GTV – Note the canopy Hinges from the front on this car



A later version of The “Puma” – Radically different from the Nova with upright round headlamps and similar “silhouette” though completely re-designed main body tub. The Roof panel is the only feature that is instantly recognisable as Nova

The South African versions of the Nova were called the Eagle and Scorpion. In Austria it was called the Ledl. France made a version called the Defi. Switzerland produced a version called the Gryff, and in Zimbabwe the car was even known as the Tarantula.

The Tarantula

This Nova derivative was based on a South African kit car called the Puma.

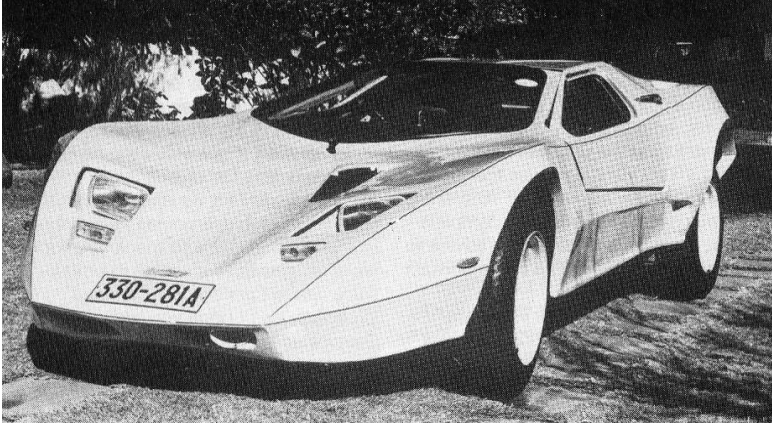

Suters of Gwelo (one of Zimbabwe's leading fibreglass manufacturers) were sold the rights to produce the car for only £1200 by a young man who turned up at their premises one day in a pickup truck complete with all the moulds and a number of windscreens. Only about 16 Tarantulas were ever made. The car is clearly based on the Nova although it is smaller overall and has Lamborghini Countach style doors.

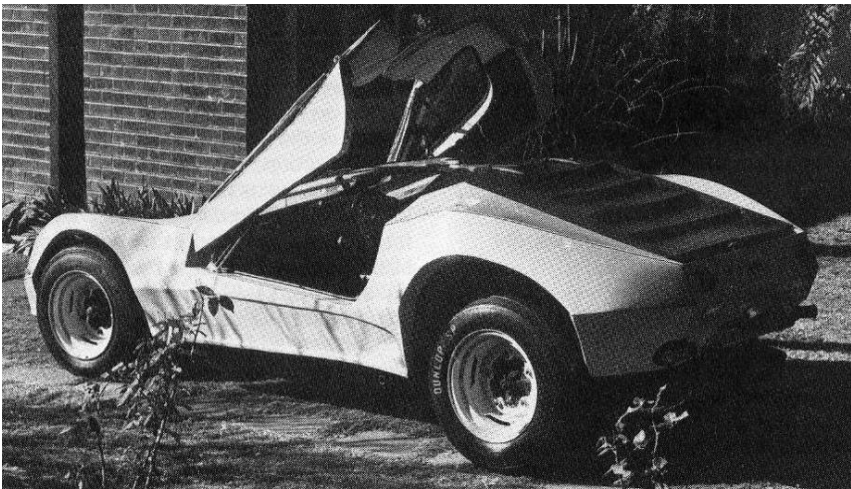

Original Nova/Sterling/Eureka

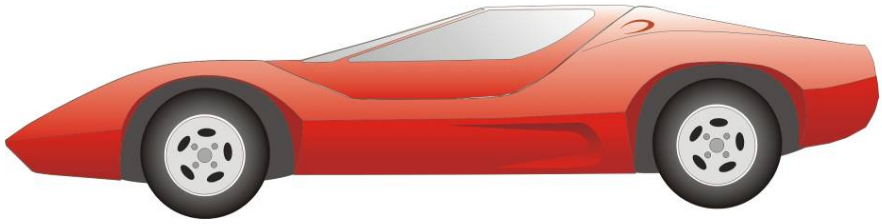

Nova Series 2



Eureka

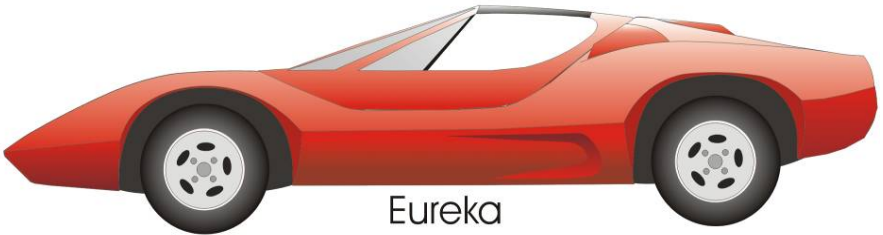

Sebring

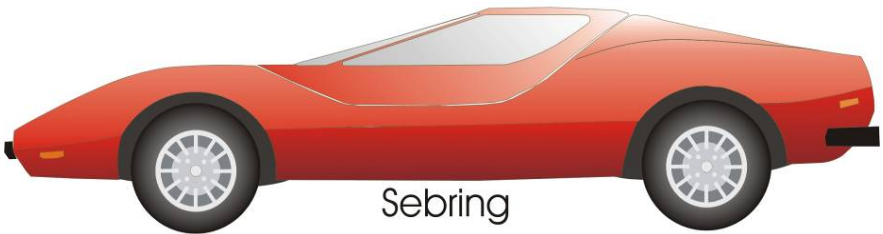

Sebring 2



Cimbria ss/Eagle ss



Chapter 3

Nova Stories

“Dragonfly” - The Electric/Petrol Hybrid Nova.



In 1980 a company called Lee-Dickens Ltd produced the “Dragonfly Nova”. This was an unusual departure for the company who’s main expertise was in industrial and military instrumentation, and humidity and temperature measurement.

Working in collaboration with Warwick or Swansea University, a car was built to demonstrate the potential of a hybrid electric/petrol driven car (using the same sort of technology behind the Toyota Prius hybrid car which eventually arrived some twenty five years later).

The Nova body shell was chosen to clothe the vehicle in order to grab public attention and demonstrate that electric powered vehicles didn’t have to just be boring “milk van” or “golf cart” type devices. Vic Elams company contributed to the project by supplying the Nova body kit.

The car was used to demonstrate the technology and raise funding for a proposed family saloon version which was to have been called the TWC-2. This car was to have had four seats and gull wing doors. The project reached advanced stages of planning with proposals for a

factory to be built in Nigeria to produce the car. London based engineering consultants, John West Associates, were behind the marketing drive. It was also rumoured that a major oil company was interested in helping to finance the project.

The Dragonfly Nova was capable of sustaining no less than 70 mpg around town (impressive economy even by today's standards, never mind in the early eighties) with an 84mph top speed and a cruising speed of 56mph. Overall, 100mpg fuel economy was achievable (to put this in context – a typical British family car only managed between 25-30 mpg in those days).

The car was driven by a 20kw twin rotor disc armature motor which drove the rear wheels. This motor was powered by eight standard car batteries which in turn were charged by an 8.2Kw generator driven by a 600cc Fiat engine running at its most efficient constant speed. For town driving the Fiat engine could be switched off and the car driven silently using only the batteries for power. The engine would cut in automatically to re-charge the batteries again once they were run down.

Despite newspaper headlines at the time proclaiming “Here Comes Wonder Car - It's on the road and purring along at 100 miles a gallon” the car quickly faded from memory and nothing more was heard about the TWC-2 project.

In 1995 (some fifteen years later) Adrian Heath (then the current secretary of the Nova Owners Club in Britain) heard about the Dragonfly Nova. Adrian decided to find out what became of the car and phoned the Company “Lee-Dickens Ltd.” to find out more about the project. The receptionist who took the call recognised Adrian's description of a futuristic looking car with a lifting roof assembly as the car that her company had been developing some years earlier. Her initial friendly response soon changed however after she asked Adrian to hold the line while she tried to put him through to the person who had managed the Dragonfly project. After a few minutes waiting, the receptionist came back on the line and told Adrian that the manager concerned could not remember anything about the car, and that it no longer existed. At that point she ended the conversation by saying goodbye and hanging up.

Enquiries to Warwick university failed to unearth any information about the project that had been undertaken fifteen years earlier.

Adrian had also discovered that Lee-Dickens Ltd were involved in Ministry of Defence work and subsequently wrote a “tongue in cheek” letter to kit car magazine in which he implied dirty dealings by the Government to hush up the Hybrid powered car project.

About a week after the letter was published, he received a strange telephone call one evening advising him that the government weren't involved in any kind of cover up. Further more, he should refrain from making these claims! On questioning the caller he was told that when an individual or small company comes up with an idea that could revolutionise society, or more importantly ruin very powerful companies or even bankrupt countries, a mystery backer will often appear to finance the project. Then just a few weeks later the idea disappears forever!

Production Figures

It has been claimed that between 10,000 and 11,000 models of the Nova and all its derivatives have been produced worldwide. My own (more conservative) estimate puts this figure at a more likely 6,000 or so. It all depends on your definition of a Nova. Do you include the Avante (another similar looking car that is not actually a direct descendant from the Nova Family) or even the Eagle SS?

UK – Nova Models

Automotive Design and Development – 180 cars

Steve Driver/Don Law Nova's – 8 cars (approx.)

Vic Elams Nova – 820 cars (approx.)

Sam Cobleys Nova – 15 cars

UK – Eagle SS – 680 cars (approx.) (VW and Ford Versions)

Total UK Production – 1706 (approx.)

USA

Sterling CCC – 765 cars

Sovran - 35 cars

Sterling GT - 50 cars

Solid Sterling - 7 Cars

Sebring - 1500 cars (approx.)

Cimbria - 500 cars (approx.)

Neria - 10 cars (approx.)

Total US Production – 2867 approx.

Australia

Eureka - 683 Cars

Hence - Grand Total = 5256 cars approx.

Note – This does not include production figures for the following derivatives:

Puma, Eagle (SA), Scorpion, Ledl. Defi, Gryff, Tarantula, or Avante

What If.....

(The Nova that could have been)

A number of events occurred from 1973 onwards that conspired to bring about the premature demise of Automotive Design and Development.

In April 1973, VAT (Value added tax) was introduced in the UK for the first time resulting in an immediate price hike for the Nova. Later in December 1973 the company re-located their base to Ayrington in the North of England which proved to be an unpopular choice for would be buyers to come and visit the Nova operation. The worlds “oil crisis” and massive inflation were the final straws that spelled the end for the dream car company.

Had these events not all occurred at around about the same time it is highly probable that Automotive Design and Development would have continued to grow and thrive.

Richard Oakes had already begun to develop his replacement for the Nova. If things had turned out differently, there is little doubt that this car would have entered into production.

The new car was to have done away with the lifting roof assembly. Richard always believed this had been a mistake and may have hindered the sales success of the original Nova (Although I personally believe the lifting canopy was one of the reasons for the cars success). The Nova MK 2 would have had conventional opening doors and was to have been a 2+2 or four seat configuration. Styling was influenced by the Lamborghini Urraco and Espada models of the early 1970's. Imagine the front end of an Urraco grafted onto the rear of an Espada and you have a pretty good idea of how the car would have looked. The Nova Mk2 would have retained its rear engine layout

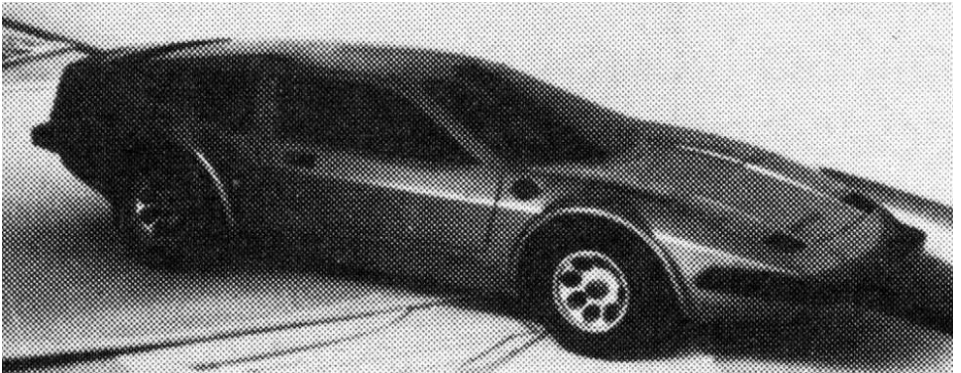
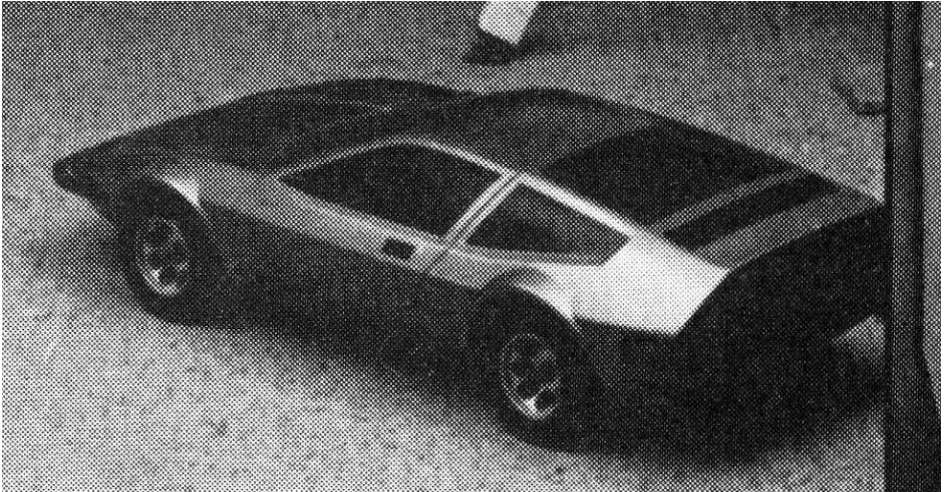

Black and white photographs showing a model of the Richard Oakes design for the Nova replacement.

The Richard Oakes – Face Lift Nova

In the late seventies Richard Oakes also proposed a “face lifted” Nova. This would have had a shorter nose with a bumper fitted at the front. The rear louvre panel would have been omitted and Countach style air ducts would have been added as well as a large number plate moulding. A single side exiting exhaust pipe would have been utilised to hide the cars humble VW origins. The car would have also featured white wall tyres and white bumpers as well as re-designed tail lights such a those used on the BL Austin Princess.

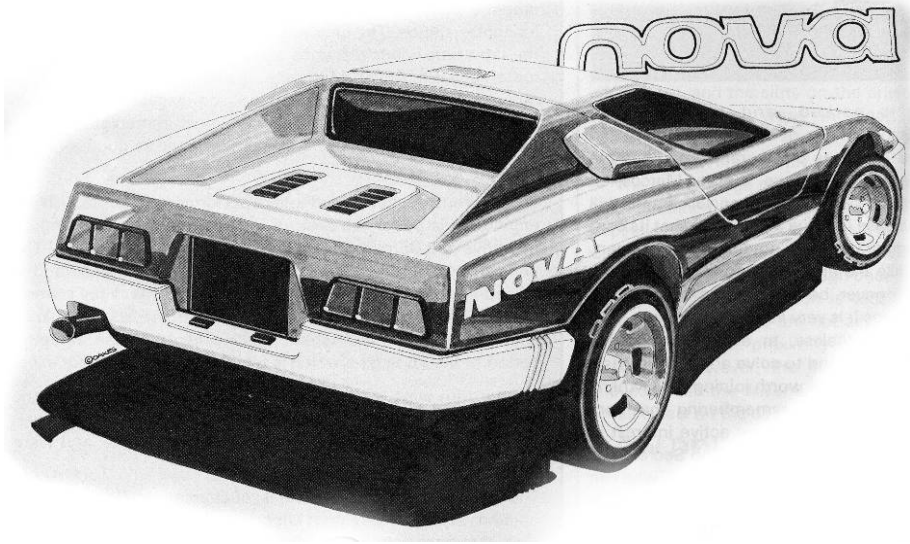

Nova Secrets

At 135 Mph the car will take off if it isn't fitted with aerodynamic aids

The pockets where the gas shocks or hydraulic cylinders mount for the top lift don't measure the same on both sides. One is shorter front to back than the other.

The body sits off centre in the rear by about 1/2 or 3/4 inch.

The Nova was originally intended to be used in the Film Judge Dredd with Sly Stallone.

The bushes in the roof hinges are the clutch pedal bushes from a Peugeot 305.

Nova is a Latin word that means "New Star".

Part Two

Chapter 4

Diary of a Build up

Introduction

In my teenage years I became aware of the Nova Kit car through reading car magazines. This car had an amazing lifting roof assembly and quickly became my dream car. I didn't care how well it drove – the fact that it looked so good was all that mattered. I was married in 1980 and by 1983 I had managed to convince my long suffering wife Alison that this should be our car of choice, and together we decided that I should go ahead and build one. Throughout the construction of the car I kept a detailed diary in which I described the whole build process. What follows are transcripts based on this diary.

The Base Vehicle

25/9/1983

My basis for the Nova was a 1970 1300 Beetle which I acquired through a friend whose niece had bought the car in order to replace the engine in her own Beetle. My intention was to fit an engine more powerful than the standard 1300 into the Nova, so the lack of an engine was of no concern at this stage. The car was towed home and work began.



My first job was to strip the car. First I removed the fuel tank, disconnected the steering column, removed the speedometer and undid all the body mounting bolts. The nearside bolts proved more difficult to remove due to severe corrosion of the bodywork inner lip where the floor pan meets the body shell (fortunately the floor pan itself was unaffected). This meant about five of the mounting bolts had to be left in place (these were subsequently removed after the body shell was off).

That evening I spent a good two or three hours stripping down the speedometer in order to zero the milometer. This proved much more difficult than expected and I eventually retired to bed with the job incomplete, only to get up during the night to finish the task! Using the original speedometer made good sense as it meant I would avoid any compatibility problems trying to find a cable that would connect to the drive at the Beetles front wheel to the connection at the speedometer. Another plus was that the wheel and tyre combination I was planning would have a very similar rolling radius to the wheel and tyre combination that was standard on the Beetle, which meant there was no need to re-calibrate the speedometer.

26/09/1983

The next day I completed the removal of the body shell. I removed the speedometer cable, rear anti roll bar, rear body mounting bolts, wiring loom (along with switches, fuse box, relay etc.). I was able to separate the body from the floor pan by lifting at each corner and inserting a brick between chassis and shell. This was repeated at each corner and so all that was now left was to physically lift the body shell clear. I then retired for a hot bath and made arrangements for some “muscle” to call around. That evening, four of us where able to lift the old shell clear to reveal a complete rolling chassis which in many areas appeared to be in remarkably good condition.



Complete rolling chassis after removal of body shell



Another view of the rolling chassis – In both pictures you can see that the front axle assembly has already been unbolted from the rest of the assembly as described next

Reconditioning the Floor Pan & Running Gear

29/09/1983

Front Axle Assembly

After disconnecting the brake pipes, the whole assembly was removed simply by undoing the four large bolts that secure it to the frame head. I had previously read an article in a Kit Car magazine which described how one of these bolts sheared off by accident and I was determined not to do the same thing. However, even after applying plenty of WD40 and exercising great care in undoing the bolts, I still managed to shear a bolt (leaving me with a broken stud in one of the threads – this was later drilled out and replaced with a large nut and bolt)!

Transaxle Assembly

I undid all the gearbox mounting bolts, rear spring ends, shock absorbers, brake hoses, and hand brake cables. The entire transaxle complete with drive shafts and hubs was lifted out of the chassis. This assembly is quite heavy and very difficult to lift on your own. I overcame this by re mounting the wheels and by placing the gearbox on a trolley jack I was then able to drag/roll the entire unit around at will. It should be noted that the large nuts that secure the hubs and drums are very difficult to undo once the transaxle is out of the car. Anyone planning to do work on the hub assemblies are well advised to loosen these nuts prior to removing the transaxle as otherwise it will be very difficult to apply sufficient torque to loosen the nuts.

Chassis/Floor pan

First I removed the brake pipes, pedal assembly, heater, clutch and handbrake cables, handbrake lever and heater levers as well as the gear change lever itself. However, the most difficult item of all was the connecting rod that joins the gearbox to the gear stick. This has to be pushed forward through the centre tunnel and removed through the frame head (there is a cover plate at the front of the frame head to facilitate this removal). I had to enlist the help of a neighbour's son whose arm and hand was small enough to fit through the opening and pull the rod through.

I now had three main sections (front axle, transaxle and floor pan) which I planned to tackle individually when it came to reconditioning them. The first job was the floor pan.

October 1983

9/10/1983

Having stripped the floor pan – the first task was to clean it up. Initially I had planned to have it sand blasted but couldn't locate any company in my area that could do this at a price within my budget. I therefore set to work with a wire brush. The underside came up very well and after a coat of Hammerite paint it looked as good as new. The top side had been fitted with insulating material glued down with a tarry substance. This tar had done an excellent job of protecting the metal but was very difficult to remove. Eventually after cleaning the surface completely, the topside was also treated to a coat of Hammerite paint.

Lowering the floor pans is highly recommended. I did mine by making up panels from sheet steel. These were cut out using a template described in the build manual. The sheet steel was cut using tin snips (which was not as difficult as it sounds). The flat panels then had to be folded to produce ledges that could be welded back onto the floor pan. A local engineering shop folded the metal for me for the very modest fee of £1.72. Incidentally it was around this time that a local scrap yard finally uplifted the remaining Beetle body shell the neighbours began talking to me again. One of the neighbours who had never stopped talking to me was called Dougie who was also a car enthusiast and had his own welding gear. He was subsequently enlisted to weld in place the new panels I had made up and also to carry out some of the other modifications to the floor pan that I was planning.



View of the floor pan with lowering panels in place (light grey in colour).



View of underside with lowering panels in place.



Top view – shows the lowering panels. In this picture you can also see the old seat runners which were to be cut off later. Also visible is the metal plate fitted to cover up the hole left by moving the gear lever assembly six inches backwards (also described later).

17/10/1983 – 26/10/1983

Floor Pan Modifications

To make the Nova as practical as possible I decided to carry out all of the modifications described in the build manual. The floor pan was sliced through with a welding torch and the flap of metal was folded downwards to allow the lowering panels to be set in place. Initially these were pop riveted and then welded up properly later.

Hand Brake Lever

Four inches were removed from its length and welded back together. Likewise the connecting rod inside the handbrake lever (which connects the push button to the ratchet assembly) was shortened by four inches.

Gear Selector Rod

Six inches were cut from its length and the tube was brazed back together again

Gear Change Mounting

The original mounting was cut out complete with the bracket that supports the connecting rod (done using a jigsaw). Another hole was cut six inches further back along the central tunnel. The mounting was temporarily fitted in place using self tapping screws (this would enable me to make minor adjustments to its position to ensure a nice smooth gear change). With the transaxle and connecting rod temporarily re fitted I was able to check the effectiveness of this modification. It's as well I did because I discovered the ends of the connecting rod had been misaligned when the tube had been brazed together. The result was I could only engage third and fourth gear. The joint on the connecting rod was subsequently "sweated off" and the rod re-brazed in its correct alignment. Once I was satisfied that everything was working fine, the gear change mounting was permanently welded into its new position and the hole left in its original location was covered up with a piece of sheet metal welded over the top.

Brake & Clutch Pedals

I hack sawed directly through these and they were welded back together again with a two inch overlap at each side which effectively shortened each pedal by four inches.

The old seat runners were cut away from the floor pan as these were no longer required (the Nova would have bucket seats fitted which used their own runners bolted to the floor).

With all the modifications complete, the joints where the lowering panels had been fitted were sealed with a mastic sealant and the entire floor pan was given another coating of Hammerite paint.

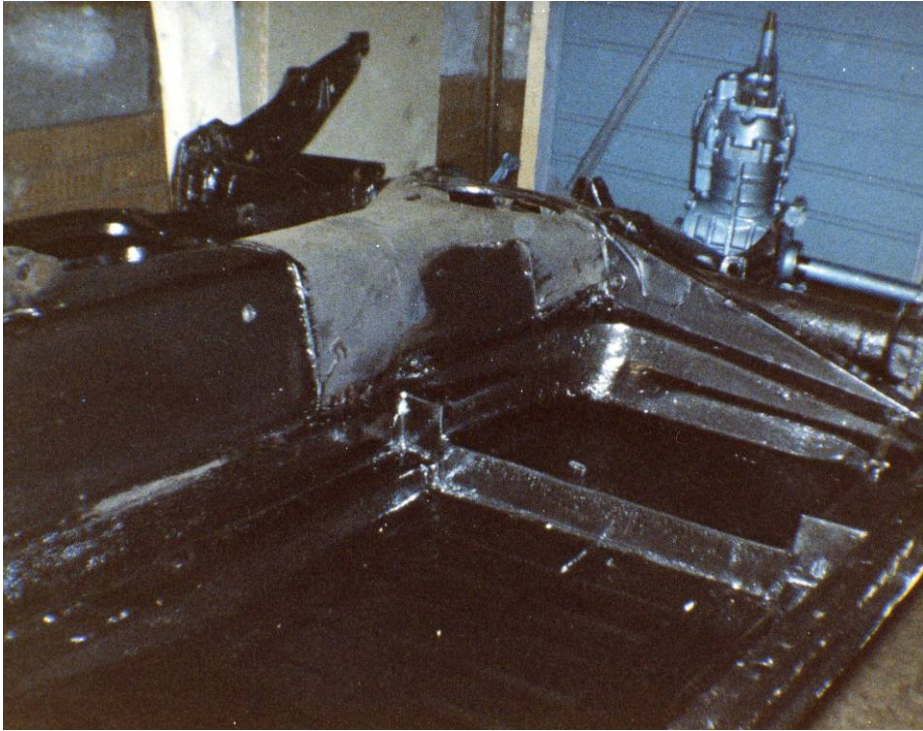

Complete floor pan with lowering panels in place after welding and painting.

23/11/1983 – 8/12/1983

Front Axle Assembly

This was stripped down as follows:

I removed the front hubs by disconnecting the shock absorbers and track rod ends, then separating the ball joints and lifting the hubs complete with drums etc. away. The track control arms were removed by disconnecting the inner track rod ends where they join onto the steering box. The steering damper was also removed and then the steering box itself. Finally the torsion arms were removed by slackening off the locknut on each arm and loosening the setscrews with an Allen key. The arms themselves then simply pull off. These four arms (each of which contain a single ball joint) were handed in to VW agent to have the old ball joints pressed out and new ones fitted (a difficult job to do yourself without the right equipment). The torsion tubes had suffered a bit of corrosion and contained a number of holes that needed to be welded up. The track rod ends (four) were replaced

with new items as was the steering box which I accidentally damaged when I tried to adjust it and over-tightened the ball race inside. Once cleaned up welded and re-painted, the main axle tubes were re-fitted to the floor pan to allow the component parts to be refitted. Everything went together quite easily with the exception of the stabiliser bar which took some time and effort using mole grips and a hammer before this part was finally re-fitted.



In this picture you can see the rebuilt front axle assembly. Also visible is the modified pedal assembly (two inches shorter than standard) and the re-positioned gear lever and shortened handbrake

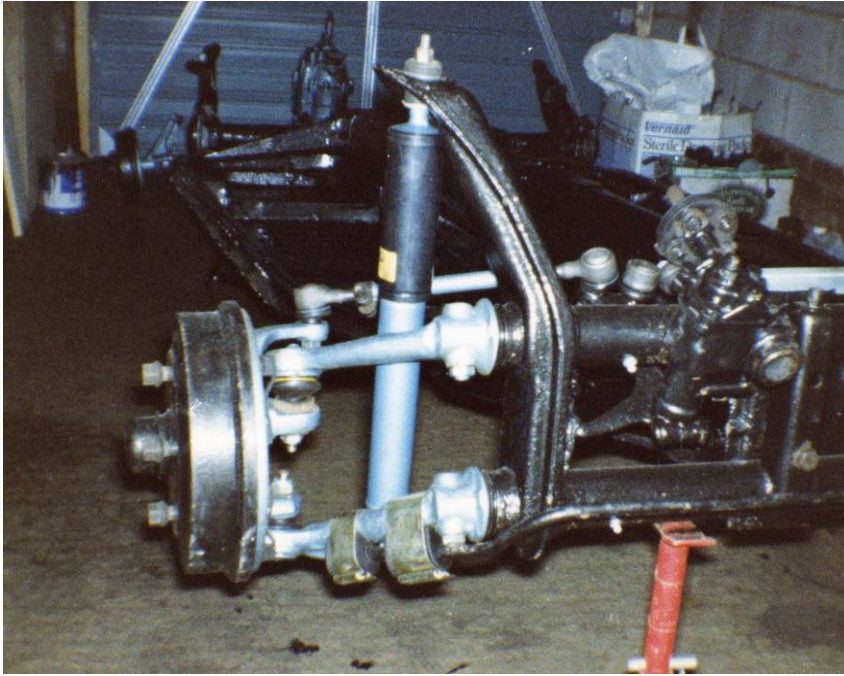

Close up view of the front suspension and hub assembly. Note the missing bolt on the frame head which was sheared off during dismantling. This missing bolt was replaced later

Transaxle

After cleaning, the entire unit was simply re-painted

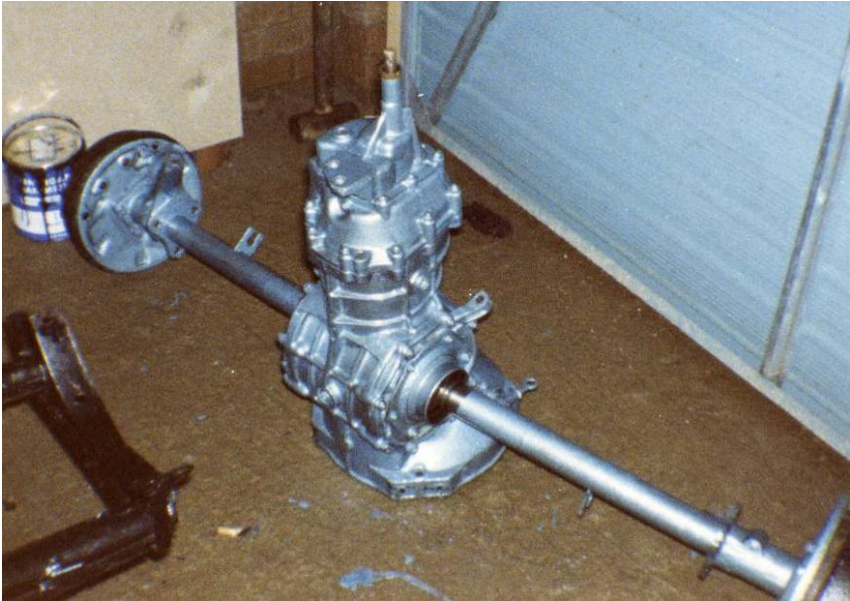

New axle gaiters were fitted (These were very easy to fit as the replacement gaiters come split along their length and simply wrap around the axle to be secured by a series of small nuts and bolts that come with the gaiter kit). A new set of gearbox mountings were used to refit the transaxle to the floor pan. At this stage I also fitted new adjustable shock absorbers. This left me with a complete rolling chassis which left only the braking system to do.



Transaxle assembly in position in the floor pan (this picture must have been taken at a period earlier than just described as you can see that the lowering panels have not yet been painted).

14/12/1983

Rebuilding the Braking System

The rolling chassis was placed on axle stands and the road wheels removed to gain access to the drums. The front drums were removed by simply slackening off the adjusters and undoing the clamp bolt on the stub axle. The shoes, springs adjusters and wheel cylinders were all removed and after wire brushing the back plate and drums were painted Hammerite blue and black respectively. While the paint was drying attention was turned to the rear brakes. To remove the rear drums a large castle nut needs to be undone. I slackened these nuts before removing the road wheels. This needs a very large socket and long handled bar (available from VW Beetle specialists) to obtain the necessary leverage to undo it. As previously mentioned the transaxle needs to be in situ otherwise it would not be possible to obtain enough leverage. The drums were drifted off the stub axle once the adjusters had been slackened off. Again, everything was stripped down including the back plates which were removed from the axle tubes.

The back plate and drums were painted blue and black to match the front ones then left to dry.

I began re-fitting the brakes by first applying masking tape over the friction pads to prevent any contamination with grease. The adjusters were liberally coated with grease and new brake cylinders were bolted to the back plates. The shoes and springs were then re-fitted and the stub axle shafts were smeared with grease. Finally the protective masking tape was removed from the linings prior to re-fitting the brake drums. At the rear, new hand brake cables were fitted and new oil seals had to be fitted to the back plates after these were disturbed when the back plates were removed from the axle tubes. New hoses and a new dual circuit master cylinder were also fitted

21/12/1983

Today I received a set of tailored brake pipes from a company called UVA and a quick shift device to fit to the gear stick. However, after fitting this I decided to remove it again as although it removed some of the movement, it also increased the effort required to change gear and I felt the gear change mechanism was better without it.

Now that I had completed most of the work on the floor pan it was time to strip it all down once again as we were about to move to a new house in the new year! I decided to separate the front axle, transaxle and floor pan in order to have manageable units that could be fitted into a large van for transportation.

January 1984

Moving house and rebuilding the floor pan assembly.

We have now moved house and have finally settled in. The floor pan, transaxle, front axle and various cardboard boxes full of VW parts were all successfully loaded into the back of the Luton van I had hired for moving.

I had been in contact with Nova sports cars to arrange for delivery of the Kit after we had moved to our new home. Unfortunately heavy snow delayed delivery of the basic kit until the 5th February.

Meanwhile, I had rebuilt the running floor pan assembly. Two evenings were spent drilling out what remained of the sheared front axle mounting bolt in the frame head. This stud was replaced with a large bolt with nuts on either end. The heater outer tubes (the ones that exit the centre tunnel into the rear of the floor pan) have also been removed with the aid of a cold chisel. The entire floor pan assembly was re-painted once again prior to re-assembly.

Chapter 5

05/02/1984

The Nova Kit Arrives

Today the Nova kit was finally delivered. About five thirty pm on Sunday a truck with a gleaming black body shell appeared outside our house. The shell was carefully lifted off the back of the truck and temporarily placed upon the almost completed floor pan in the garage. Various other panels were stored in the spare bedroom. The rest of the evening was spent admiring the new body as it sat in place on the floor pan.



Body kit temporarily sitting in place on the re-built floor pan

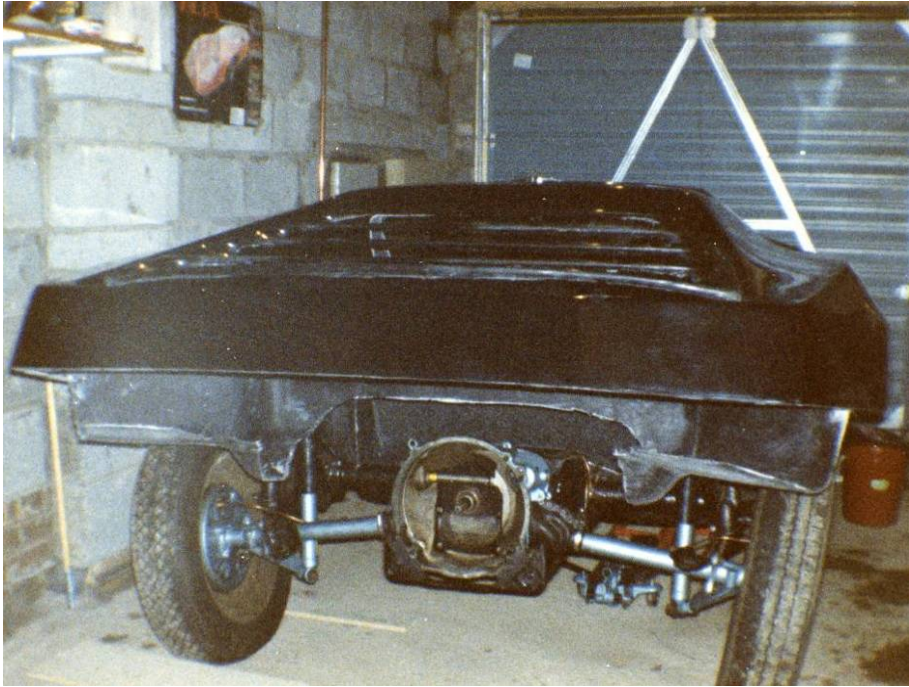

07/02/1984

To make space in the garage where the build up was to take place, I removed the factory fitted roof section and tried to take this upstairs to store in the spare bedroom. However, I discovered it would not fit up the stairway. After careful negotiation with Alison it was finally agreed that the roof section could be stored downstairs in the dining room of our new house!

14/02/1984

Much has been done since the body shell arrived. The main tub section is now suspended from the rafters in the garage giving me access to complete the work on the floor pan prior to permanently fitting the body shell.



Main body tub section suspended from rafters in the garage

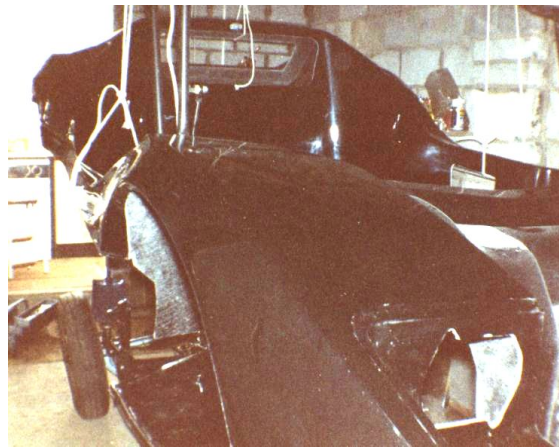

The final preparatory work on the floor pan was as follows:
Waxoyl treat the centre tunnel (Rust proofing). Torque down all the bolts to their respective settings. Fit all copper brake pipes and tighten all brake unions. Re-fit clutch and handbrake cables. Re-fit pedal assembly. Mount rubber gasket on floor pan (this is the seal that fits against the flange of the new body shell). Grease all grease nipples. Re-fill transaxle with oil. Adjust position of steering box.

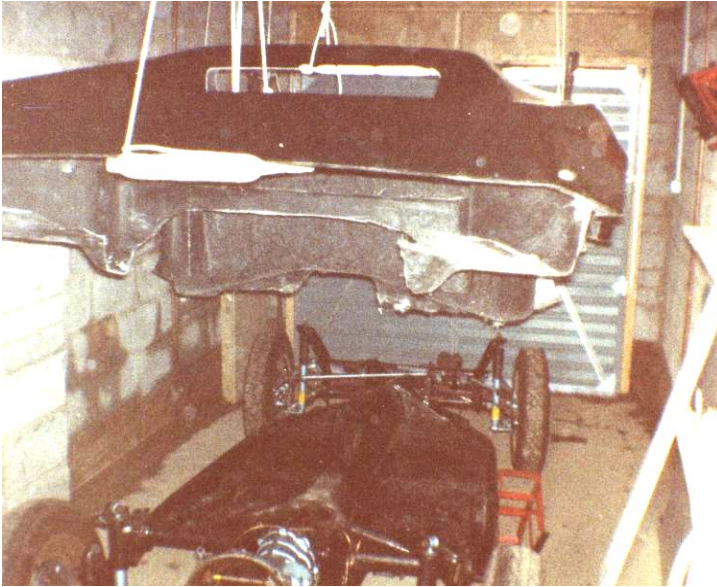

The Main Body tub shown suspended above the completed floor pan which was now ready to be joined together.

26/02/1984

Fuel Tank Installation

The old Beetle fuel tank was cleaned up and steel plates measuring 16” x 4” were riveted to the flanges on the sides of the tank. The whole assembly was painted Hammerite blue before it was installed into the body shell by bolting it in place with four nuts and bolts and large “Penny” washers.

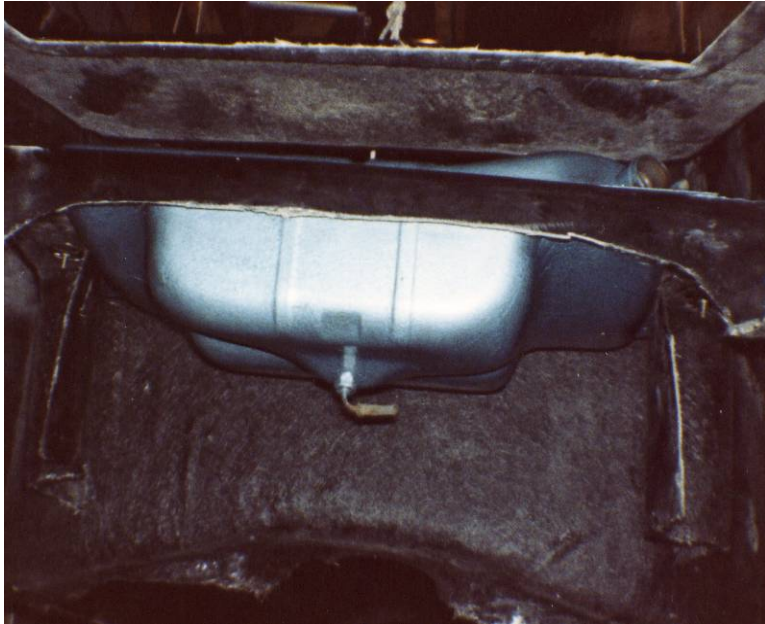

View of the empty engine compartment showing the fuel tank in position in the body shell behind the rear bulkhead

03/03/1984

Fitting the Body Shell

After test fitting, the mounting flange on the body shell was trimmed to size to enable it to nestle down properly on the floor pan. Further trimming was required to allow the shell to clear the master cylinder and pedal assembly. Once satisfied that everything fitted, sealant was applied over the rubber seal (floor pan gasket) and the body placed on top. With the body in position it was checked for correct alignment (square ness) by measuring the distance from the shock absorber mountings to the outer edges of the wheel arches. Once "square" it was bolted into its final position by drilling up through the original mounting holes in the floor pan through the fibreglass flange (and rubber gasket). Half inch nuts and bolts with large penny washers were used to bolt the shell down.

View of Body shell now permanently in position on the floor pan



With the main body tub fitted it was now possible to re-fit the roof panel. The rear louvre section was also fitted at this stage using brass door hinges.

06/03/1984 – 15/03/1984

Fitting the Body panels

The rear under skirt. This proved very difficult as the panel didn't seem wide enough to fit the shape of the body flange that it needed to bolt onto. In addition, the flange on the body shell wasn't wide enough in places to accommodate the penny washers I was using to spread the load once I had bolted the panels together. I ended up cutting straight

edges across the washers (making them half moon shaped) to make them narrow enough to fit the flanges. After much struggling and effort I eventually persuaded the panel to fit. What worried me most though was it actually said in the build manual that this was one of the easiest panels to fit!

I also fitted the rear mounting brackets supplied with the kit. These bolt onto the rear shock absorber top mountings and against the side of the engine compartment.

07/03/1984

Fitting the side panels

This proved to be easier than I was anticipating (the shape of the panel turned out to be a better fit than the shape of the rear skirt). First I clamped the panel in position and using masking tape I marked the positions where I wanted to drill the holes for the bolts to pass through the body and the side panel flanges. The clamps were removed and holes were drilled through the corresponding flanges exactly 2 cm in from the outer edge of the panels. The panels were then bolted into place using 1 ½ x 7/16th bolts, nuts and penny washers. The only difficult part was in doing up the bolts in the middle to front section of the car as access to this is limited as it has to be done by reaching through the glove box holes in the cockpit sides.

Altogether a very satisfying day.

12/03/1984

Fitting the front under tray panel

Surprisingly, this turned out to be the easiest to fit. First the panel was held in position using a trolley jack to lift the under tray up against the bodywork. As with the side panels, positions were marked on the tray and body to show where the bolt holes should be drilled and these were bolted in place using the same types of bolts and washers as used on the side panels. The front leading edge of the under tray was fastened to the body using very large self tapping screws (as access to the upper section of the flanges was not possible).



Views of the car complete with front under tray and side panels fitted



15/03/1984

Today I fitted the master cylinder fluid reservoir into the front compartment of the car. This was secured with a strip cut from sheet metal and secured to the body using self tapping screws. I also cut an access hatch into the rear of the front compartment to give me access

to the steering box. This access hatch was then covered up using a sheet metal plate that was held in place using small nuts and bolts. The original Beetle pipes were used to connect the fluid reservoir to the master cylinder. The braking system was now complete, requiring only bleeding and brake shoe adjustment.

The steering column was now positioned roughly in position. I drilled a large hole in the bulkhead and used a file to open it up until it was large enough to allow the steering column to pass through. A metal cover plate was made up from sheet steel to allow the position of the column to be varied. This would be fitted permanently to the bulk head once the final position of the steering column (where it passed through the bulk head) was known.

26/03/1984

The dashboard was fitted and bolted roughly into position using only two bolts at this stage (to allow later adjustment if required). The steering column was bolted to the underside of the dashboard using brackets saved from the Beetle. The seats were then bolted to the floor using the sub frames supplied with the aftermarket seats. With the seats in their final position I am satisfied that if I hadn't made the modifications to the floor pan described earlier I would not have ended up with such a comfortable driving position.

16/04/1984

The Engine

Today I bought a VW Variant 1600 Fastback.

I was at a scrap yard on the look out for an engine to use in the Nova when a VW Variant turned up ready to be sold for scrap. I cheekily managed to speak to the owner before he spoke to the dealer and I bought the car for £40. The engine is a 1600cc pancake engine complete with twin carburettors. The engine ran well despite the car showing 95000 miles on the clock.

Since my last entry I have done very little to the Nova apart from bolting metal bars to the underside of the dropped floor pan area where it used to flex. The addition of the bars has stiffened it up substantially.

I have also recently bought a set of 205/70 x 14 Firestone tyres advertised “as new” in the local Motor Mart magazine. The set of four tyres cost me £110 and I also ordered a brand new set of 7x14 Keystone Turbo master wheels.

09/05/1984

Wheels and Tyres Fitted

The wheels and tyres have now been fitted to the car and it’s beginning to look the part.



Views of the car with wheels fitted. Note the rear wheels still need to be de-cambered as the car sits high due to the lighter bodywork.

Yesterday I removed the engine from the Variant (this was very easily done. Air cooled VW engines must be about the easiest of engines to remove/fit). With the engine out my first job was to remove the heat

exchangers. These were rusted through and will be replaced with new Beetle (Type 1) instead of the original Variant (type 3) exchangers. This was necessary to accommodate the “Bugpack” exhaust system I was planning to fit. Another “plus” was that the type 1 heat exchangers are less expensive than the type 3. Other parts removed from the Variant were the handbrake cover and grip, Gear knob (Much chunkier than the Beetle item) and the battery. With all the usable parts salvaged from the Variant, the car was then towed to a scrap yard for disposal.

With the engine out, all ancillaries were stripped from the engine (Exhaust, heat exchangers, cooling system and other removable parts). The shrouding for the air cooling was cleaned and painted. The basic engine was then hung onto the gearbox in the back of the Nova (Very easy – just four bolts hold it in place). With the basic engine fitted I then degreased the unit (by painting it with “Gunk” a proprietary cleaning solution). With the engine still in the car I then began refitting the shrouding of the cooling system and the cooling fan. Engine access was far easier than I had anticipated as with the rear underskirt panel removed it was very easy to reach in all around the engine. The car is now sitting with most of the engine ancillaries fitted but will have to be removed again in order to fit some of the upper cylinder cover plates and a new clutch.

28/05/1984

Lowering the rear suspension

With the much lighter body of the Nova the rear suspension sits much higher than on the Beetle which results in the rear wheels tucking in at the back. To counter this, the suspension has to be lowered (I decided a two inch drop was necessary to produce a suitable ride height and effectively de-camber the rear wheels). The rear torsion bars have splines on their inner and outer ends (44 at one end and 40 at the other – this corresponds to a change in angle of 8 and 9 degrees).

After making a scale drawing I was able to measure the angle of rotation required on the spring plate to lower the suspension by 2 inches. This angle worked out to be 8 degrees which meant all I had to do was remove the spring plates from the torsion bars and refit them one spline further around (obviously any angle can be achieved using a

combination of inner and outer rotations of the torsion bars). With this adjustment made, the car now sits at about the right ride height.



View of the car after lowering the rear suspension



07/06/1984

Completed engine work

After removing the engine again, all the cleaned and re-painted ancillaries have been re-fitted. New gaskets were used at the inlet and outlet ports of the new heat exchangers.

Some of the fibreglass bodywork had to be trimmed back to prevent the type three engine from rubbing against it. The engine was re-fitted along with a new clutch plate. A hole was cut into the back panel to house the oil filler and dipstick. The dipstick also had to be shortened considerably because I mounted the filler aperture low down on the back panel beneath the bumper.

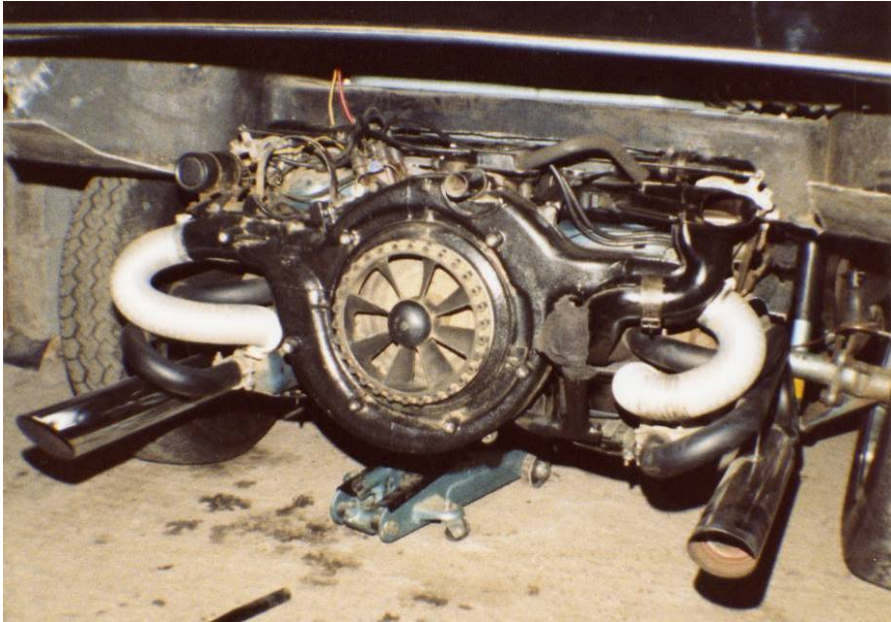

Here you can see the engine installed in the back of the car. The rear skirt is off the car at this stage which allows excellent access all around the engine.

26/6/1984

Steering column installation completed

I finally got around to finishing off the steering column installation. The original hole cut in the bulkhead was much larger than it needed to be. As a result, the outer sleeve of the column was resting on the inner column. To rectify this I manufactured a metal plate with a hole of the same diameter as the rubber grommet removed from the original Beetle. This grommet ensures a watertight seal where the steering column passes through the bulkhead and was fitted onto the metal plate I had made up. This in turn was fastened to the bulkhead of the Nova and fixed in place using self tapping screws. The column was then re-connected to the steering box. The dashboard panel was re-fitted and the upper section of the steering column was bolted to the dash. However, at my first attempt I found the steering column outer sleeve still fouled on the column inner, so I took out the dash again and the metal plate was re-positioned correctly so that the inner column was centralised in the outer sleeve. The steering column now has a “manufactured” feel to it and the metal plate will eventually be

permanently fitted to the bulkhead using nuts and bolts and by glassing it in place.

Up until now I have never been entirely satisfied with the fit of the roof panel against the bodywork. The problem was it sat about a half inch too high at the front. Having tried the adjustments described in the build manual, I eventually decided to re-site the roof hinges two cm further back. This would prevent the lower edge of the roof hitting the gas struts fitted to each hinge. With the hinges re-sited the fit of the roof showed a big improvement, but the driver side leading edge was still slightly high. To rectify this, I sanded down the area where the gas strut was still touching the roof. This has resulted in a very snug roof fit much more like the kind seen in the factory brochure pictures. Once the roof seal is fitted I expect to have a nice watertight joint.

Chapter 6

05/07/1984

Driving the Nova for the first time!

Much has been done since my last entry. The gear stick was shortened by removing 85 mm from the shaft and rejoining the two halves temporarily with a piece of Dowling (eventually it will be welded together permanently). While the dash was out I drilled holes in the bulkhead to route the speedo cable to the front wheel hub. The original Beetle Speedo was installed in the dash and the two ends of the cable connected up.

I also completed the installation of the fuel system. A “flip top” filler cap was installed by drilling a hole on the cars off side rear wing. The filler was fitted into the hole and connected to the fuel tank using a combination of the original Beetle hose and some hose sections taken from a couple of Rovers at the local scrap yard. A venting system was also installed using original Beetle hose exiting from the fuel tank onto the Novas rear deck. Fuel lines feeding petrol from the tank to the fuel pump and on to the carburettors were also installed and the fuel system was ready.

Having also bled and adjusted the brakes, I felt that the car was at a stage where if only it had an electrical system it could actually be driven!

A gallon of fuel was siphoned off from the fuel tank of my daily car and poured into the Novas fuel tank. I also rigged up a battery to enable the engine to be started. This involved running some temporary leads from the battery to the solenoids on the carburettors and to the ignition coil. Jump leads were then used to energise the starter motor. However, try as I might, I couldn't get the engine to start. The only thing I achieved was to discover an oil leak caused by an oil seal being incorrectly fitted. This leak took half a day to fix as I had to remove the rear panel and remove the carburettor and shrouding situated near the oil cooler to get at the offending seal

The next day I decided to make another attempt to start the engine. With Alison in the driving seat, and all connections made to provide electrical power to the engine, my friend Richard, myself and a neighbour attempted to push start the car. At the third attempt the engine fired up. Alison switched over to the passenger seat and I climbed in the car and together we drove into a field behind our house. The brakes, steering and suspension all worked and the car felt really great to drive at last! The top speed was restricted because of the bumpy field. Eventually the car was driven back to our house having clocked up 0.3 miles.

Driving the car for the first time was a great boost to my morale and I was beginning to feel the car was almost complete.



In this picture, my friend Richard can be seen driving the car.



The Nova being driven at speed?



Me and Alison in the car

14/7/1984

The car has now been driven in the field behind our house quite a few times, on one occasion reaching a maximum speed of 25 mph! The car

is very noisy due to not having a rear window fitted and no interior trim. Otherwise it feels very good to drive. I also discovered that the front wheels rub against the wheel arches when on full lock. The rear suspension has settled quite a bit and the back of the car is now resting on the bump stops! This now means the rear suspension will have to be raised back up again.

I also discovered that I had re-assembled one of the carburettors wrongly which resulted in the choke not working properly. With this fault rectified the engine now runs very smoothly. The car has very good acceleration due to the lighter fibreglass bodywork and the "Bugpack" exhaust system which has been fitted.

The next stage will be to trim the interior.

24/7/1984

I am now getting around to the 1,001 minor details that need attending to. I have replaced all the fuel lines (original ex Beetle) with brand new hoses and jubilee clips. I also re-painted the rear louvre panel matt black (the original gel coat finish wasn't up to the same standard as the rest of the cars bodywork. Likewise, the rear bumper panel was also re-painted). I also fitted "Hood pins" to hold the louvre panel down onto the bodywork.

Inside the car I have fitted clips on either side of the interior to hold the roof section onto the body (it was bouncing up and down when the car was being driven).

21/10/1984

Little progress has been made for the past few months. This was due to a lack of parts and the fact that Alison and I decided to use our money to go abroad for our summer holiday this year. With the holiday behind us it was time to get back on track with the car. Last weekend we headed south to the Nova factory at Bridge Garage, Mirfield, West Yorkshire to purchase more parts. This consisted of a purpose built wiring loom, lights, wiper motor, and an electric hydraulic roof lifting mechanism. I had originally planned to keep the costs down by using a manually operated roof system. However, I soon discovered the

manual system to be fairly inadequate. Alison struggled to open the canopy on her own, and the roof tended to bounce up and down when the car was driven. The addition of two catches at the sides of the cockpit failed to cure this. The hydraulic system with its negative pressure (pressing the canopy down onto the main body tub) should alleviate both problems completely.

The car has also now been trimmed and carpeted. The carpets were cut to size in situ and fastened to the floor pan using professional fasteners. I also made up trim panels inside the cabin by transferring the shape of the cockpit sides onto millboard (a sort of hardboard material). This was covered with 1" foam and vinyl leather cloth material. Finally each panel was "buttoned". The result was a professional looking interior with the added advantage that the panels could be easily removed for cleaning. The glove boxes and dash board were also trimmed with simulated leather cloth (the dashboard in black to prevent unwanted reflections on the front screen – all other panels were finished in a creamy off white, which helped to make the cabin feel less claustrophobic).

Headlamp covers – these were made from 2 mm clear acrylic which was cut with a jigsaw, I also made the back window in the same way.

After returning from the Nova factory I began work on the wiring and hydraulic roof assembly. First I laid the wiring loom out in my living room to familiarise myself with the layout. I then carefully labelled every single connection before proceeding to route it in the car. It is now correctly positioned and held in place with electrical tie wraps (although no connections have yet been made).

The gas rams have now been replaced with hydraulic jacks (Incidentally, I eventually had to revert back to the original position of the roof hinges as I found the hydraulic jacks worked more smoothly with the roof in this position). The hydraulic pipe work was routed in a similar way to the wiring loom.

Chapter 7

November 1984

Completing the car and final registration

The final stages to complete the car were as follows:

Wiring – With the loom already routed in the car and all the connections labelled, it was a straight forward job to connect everything in accordance with the Nova build manual.

Lights – The headlights, rear light clusters, indicators and number plate lights were fitted to the car and the connections made.

Wiper Motor – This should have been straightforward but unfortunately I drilled the holes for the wiper motor and slave arm in the wrong position on the roof canopy. This caused the wiper motor to foul against the bodywork which prevented the roof from closing properly. The position of the motor had to be moved and the wrong holes were covered up using rubber grommets. The wiper motor wiring runs up the parallelogram hinges and through a box section in the roof. Routing the wiring was tricky but eventually it was achieved using a wire coat hanger bent to shape to pull the wiring through the box section.

Windscreen Washer – I decided not to install the washer nozzle on the roof section as I wanted to avoid the complication of running the feed hose through the box section in the same way as the wiring. Instead, the spray nozzle was installed on the front compartment lid (boot lid). The only thing I have to remember is not to operate the washer when the canopy is open otherwise I get a jet full of water in the face (good fun when demonstrating the system to someone else though). The washer motor was fitted inside the front compartment and a Beetle washer bottle was used (from a 1303 series Beetle). With the electrical connections made, the system works perfectly.

Engine – The connections to the engine are as follows:
Two connections to the dynamo (these had to be lengthened to accommodate the type 3 engine I had fitted). An ignition controlled

live supply to the coil and carburettors and a single connection to the oil pressure switch.

Hydraulic Roof lifting Motor – The Nova loom contains all of the connections necessary for the roof hydraulics. This comprises a solenoid, modified headlamp change relay, key switch and push button switch. With everything in place, the hydraulic system was filled with the correctly specified hydraulic fluid. There are no bleed nipples anywhere so I had to leave the pipes disconnected at the ends where they should connect to the lifting jacks. I then ran the pump until all the air was expelled from the system. I then re-connected the pipes to the lower part of the hydraulic jacks and ran the pump again until both jacks were fully extended. The upper pipe connections were then made and that was it. With the canopy bolted back onto the roof hinges the system was tested and found to work perfectly with the roof opening and closing with a steady smooth action. The roof stays level and glides impressively up and down when operated. A huge improvement on the manual system and pretty sensational to watch!

All of the relevant switches were fitted onto the dash board and the steering stalk and key switch connections were also made. The Nova loom picks up its power from a connection at the starter motor. I ran a heavy duty cable from the positive side of the battery (fitted in the front compartment) along the driver side sill all the way to the starter motor in the rear of the car. The Nova loom then connects on from the starter. The only earth connections required are one from the negative post on the battery to the floor pan, and one from the Nova wiring loom (all the earths are included in the Nova wiring loom coming together as a bunch of cables that require only one good connection to the floor pan). Altogether, installing the wiring was very straightforward following Novas detailed instructions and nothing like as difficult as I had imagined. With the loom fully installed everything worked correctly first time.

Heating System

Novas are well known for problems with the screen misting up. For this reason I wanted to install a heating/demist system that was as efficient as possible. I therefore decided to duct all of the air from both heat exchangers directly onto the screen. Under the dash I glassed in a “U” shaped piece of fluted ducting and drilled a number of small holes

at the top of the dash where I wanted the hot air to come out. Fluted tubing was connected to the glassed in “U” section of tubing and ran along the sides of the car to be connected to the heat exchangers at the rear. These heat exchangers are operated in the same way as the standard Beetle using levers and cables controlled from inside the car.

Seat Belts

I used a set of static belts taken from another Beetle. These were bolted to the centre tunnel (using the standard Beetle fitments) and towards the rear of the side panels where the fibreglass is at its thickest. I drilled holes through the fibreglass and mounted the belts using the bolts saved from the Beetle. These pass through the fibreglass and bolt into threaded steel plates positioned behind the panels (these plates were bought from a local company).

And that was it!

The next day the car passed its MOT test first time, and after registration (I received a “Q” reg.) It was finally ready for the road!



Early first drives in the Car – My mother is in the passenger seat.



My Wife Alison beside the newly registered car

14/12/1984

First Driving Impressions

The car is now completely finished, road registered and legal. So far I have covered over 500 miles in the car. Performance and handling are very good with the car probably feeling quicker than it really is due to the driving position being so low.

Initially the canopy section creaked quite a lot but I soon discovered that this was due to the heads of the self tapping screws used to secure the roof seal rubbing against the body shell. These I removed (the seal was also glued in place so I didn't really need them anyway) which has almost totally cured the problem.

I have left the damper settings at their softest as I found the car was very uncomfortable when the dampers were set at anything else but their softest position (probably because the Nova is so light and the dampers were really intended for the much heavier Beetle body shell).

These cars really do need to have the hydraulic roof and lowered floor pans to make them practical.

Overall the total cost of the project has been just over £4,000 (in 1984 a brand new Ford Capri 2.0 Laser cost about £6,000 to buy new). However, the car is almost as new with the exception of the engine which was fitted without any re-conditioning.



Me and my Father sitting in the car

Chapter 8

February 1985

Disaster Strikes!

A little over two months since the car was completed, I was involved in a road traffic accident in the Nova. On a snowy day in February 1985 I was pulling out of a road junction turning right when the car was hit on the driver side by a Triumph Dolomite. This caused substantial damage to the Nova.



The Triumph Dolomite that collided with the Nova



Side view showing the damage to the Nova



Interior view after the accident. – This is one of the only pictures I have that show the original interior trim



View of the front compartment after the accident: This picture shows some of the detail described earlier. Here you can see the steering box cover plate, the windscreen washer installation, Brake fluid master cylinder and the battery.

To repair the car I had to remove the body shell and weld in a new floor pan on the driver side. I repaired the damaged section of the main body tub using fibreglass and filler. The lower side pod was replaced with a new item bought from Nova Sports Cars. During the re-build I decided to re-spray the car red and fitted a removable sun roof. I had been trapped in the car after the collision when the hydraulic canopy failed to open and the addition of a sunroof provided much needed ventilation and a means of escaping in an emergency. (My passenger and I escaped from the car at the time of the accident by pushing out the acrylic side window and climbing out).

The rebuilt car was used as daily transport until August 1986 when I eventually sold it.

Postscript

So why did I sell the car? To be honest I think it was mainly because the Nova has such an extrovert appearance which makes it difficult to live with. I suspect that driving the Nova is a good taste for what it must feel like to be famous. It draws a lot of attention which makes you feel very self conscious. Some people may welcome the attention it brings them but this can quickly wear thin after a while.

Richard Oakes the designer of the car appreciated this fact. He once said “I don’t like driving the Nova about because I hate being looked at and watched. You get in and out of it and the lid goes up and everybody looks and thinks you’re something you’re not. I really don’t like that at all”.



Views of the rebuilt car re-sprayed red

A few years later I saw an advert for a Nova for sale in my local Autotrader. I was intrigued enough to make an enquiry about the car and discovered it was the very same one I had built some years earlier. I decided to go and view it as I was tempted to buy it back. Unfortunately the car had been badly neglected. It had been vandalised at some point when paint stripper or brake fluid had been poured across the bodywork whilst the windscreen had been broken and

replaced with an illegal acrylic panel. With it being in such a sorry state I declined to make an offer.

I often wonder what became of it. If anyone knows, please write to me c/o the publishers address. The cars registration number was Q388 WFS.

And what became of the Dennis Adams Probe– the car that started it all for me?

Around about 1977 I drove a friend to a back street garage in Edinburgh to pick up his car which had just been serviced. During our conversation with the owner of the garage I described my ambition (back then) to build a Nova Kit car.

“I’ve got something that would interest you ” he replied, and he took me into a section of his garage where a partly deconstructed fibreglass car was stored. I recognised this for what it was. An original Dennis Adams Probe 2001.

I also often wonder what became of that car.

A Modern day Nova?

So what would be today's equivalent of the Nova if such a car was brought to the market today.

Saab recently produced a design exercise featuring a car with an opening roof section. This is simply a show car and there is no intention to put this car into production.



My Ideal Nova

Over the years there have been many attempts to update the Nova. Both Individuals and manufacturers have developed the car from the original Richard Oakes design. In particular attempts have been made over the years to increase the interior headroom for the cars occupants. This has involved a combination of raising the roof-line while reducing the rake of the windscreen. However, my personal view is that the original design was never improved upon. To my mind the original Nova and Sterling from the 1970s was the most beautiful of all. This car had the nostril intakes on the front bonnet which were removed in later years (I never understood why they were removed). The higher roofline on later models may have made the car more comfortable but this was at the expense of the cars styling (it simply looked better with the lower roof). The Sovran with its squared off arches was a mistaken attempt to update the cars styling

The Sebring was a fatter more ungainly version of the car that had lost the air intakes from the side and looked like a more bulky car. The Cimbria with its gull wing doors was a brave attempt to improve the styling which resulted in a car that was substantially different from the Nova but still not as beautiful.

The Purvis Eureka open top roof panel was to my eyes a success.

Various engines and engine configurations have been attempted over the years both by owners and manufacturers. Various water cooled engines have been tried over the years and mid engined layouts have been attempted. Non VW chassis have also been tried with varying degrees of success. Again to my mind the best solution was still the original air cooled VW engine and modified floor pan.

So if I was to build a Nova today, what would I build?

It would have to be based on an original series one body from Southampton. The running gear would have to be VW with front disc brakes and a double jointed transaxle as used on the automatic 1500cc VWs of the late 1960's. The engine should be a 1600cc or 1800cc air cooled VW.

Wheels – A set of Turbo Vec alloys would be ideal, or perhaps the more traditional Wolfrace slot mags as seen on most early cars.

I would have a spare (open) roof for the car. Either a Purvis open top, a Mike McBride open top, or a Bermuda open top from the Elam era.

And what colour would the car be? Perhaps silver because I've never seen a silver Nova. Alternatively, lime green should be the colour of choice - lime green from the early seventies because this would be a fitting tribute to Richard Oakes the genius behind it all.

Appendices

Interviews

Richard Oakes – The man behind it all

Richard Cobley – UK Manufacturer from 1993 until 1997

Mike McBride – US Manufacturer from 1995 until 2005

An interview with Richard Oakes

(The genius who designed the Nova and started it all)

(September 6th 2006)

Q How did you produce the original mock up for the car. Was this produced from detailed drawings or was the pattern “sculpted” and made up by trial and error?

We did it the way we always do it, by using plywood and polyester filler. That’s pretty standard really.

Q And did you have accurate drawings that you worked from or was it basically sculptured?

Yes it was basically sculptured

Q So, you’re like an artist working rather than an engineer?

Well what you have to do is do part of the engineering and part of the pattern making at the same time because you’ve obviously got to work around the mechanical bits so it’s a mixture really of the two things. People often think you make a big plaster pattern using plaster and chicken wire but you can’t really do it that way because the pattern making and the engineering are done at the same time. You really need things which will stay separate so you can separate bits at any time and also fit around the mechanical parts. With cars there’s a lot of close fitting stuff so that’s really the best system to do it. It’s also best to stay with polyester for all the materials (pattern and mould) so you don’t get any strange reactions going on. It’s also very stable, as polyester is not de-stabilised by moisture or temperature.

Q Looking back, was it a good experience running Automotive Design And Development. What were the highlights, and what were the lows?

It was a real thrash to do it. Because a chap called John Willment was sponsoring it. Phil and I put in an estimate of what it was going to cost

and it was just hopelessly inadequate as these things are – because it's very difficult to estimate things like that.

It took a year to make all the patterns and the moulds and do all the bits of engineering and stuff, (which by today's standards is pretty quick for that amount of surface area). We also wanted it to be self finished so it also had a gel-coat finish which is something I can't be bothered with anymore because it's just so difficult to do. Also, things that are gel coat finish just look like kiddies paddling pools. There's nothing like paint to make it look like a car. But in those days it was fine. It was just an extension of beach buggies really.

Q What could you have done better with the benefit of hindsight?

In my sons room there is a model of a car which was going to replace the Nova and it's kind of what it really should have been I think. The lifting top is what really used to irritate me because it was so ambitious to get that thing to fit. It was kind of naive to try and do that because it was a double skinned moulding and it had to fit the outside shape of the lower tub every time in a sort of passive way whereby you weren't trying to pull it into shape every time. It just had to land in the right place. And it was extraordinarily successful considering what a gamble it was. But I always hated it because in the winter it would just fill up with snow and let all the warmth out of the car when you were getting in and out.

Q And yet to my mind that's what really made it and what people loved about the car?

Yes I think that's probably right Phill, but for me it was just an irritating thing.

Q Do you ever regret selling on the rights to produce the Nova?

No I don't anymore. We put the company into voluntary liquidation because there just wasn't any more business to be done. In 1975 because of the oil crisis we went from having about nine months worth of orders to practically nothing within a couple of days because people were just cancelling orders. Suddenly people didn't want things like that anymore and so that was that. That was the point at which Phil

and I separated, but my wife and I carried on for about eighteen months. But in the end we just asked our accountant to put it into voluntary liquidation because there was just no business to be done. We were struggling against impossible odds really. And the interest in that type of car didn't re-emerge until a few years later (but by then I had lost interest and had moved on).

Q Presumably that's when Vic Elam got involved?

Well not really, he'd become involved a few years earlier. He was an opportunist and perhaps he just thought this was going to come back again. But I didn't have that sort of confidence and I just wanted to move on because by that time I was just tired with trying to make it work. We did do about 179 cars in just two years or so which was fantastic. But the move up to the North of England was a complete disaster really.

Q And was that because Phil Sayers had wanted you to move?

I'd have been very pleased if we had stayed in Southampton. When we were in Southampton we could get people to come and see us from all over the country including Scotland, but once we moved to Lancashire it was like no one wanted to come and see us there. It may have been partly the oil crisis that did that (the economic climate had changed), but there was more to it than that. There was nothing exotic about going to Accrington to see something, whereas Southampton seemed to be okay. Accrington was a real struggle.

Q How do you feel about the cars that were copied from your design (The Cimbria and Sebring for example - I'm assuming these weren't licensed copies), did you resent them?

No, not at all. I mean it has to be a compliment isn't it? I was aware of those things at the time. The Cimbria? Wasn't that created by a restaurant owner in Nebraska or something?

Q Joe Palumbo?

Yeah that's the guy, I'd forgotten his name.

In fact those were good times. When we went out to California to help them to set up the Sterling, that was definitely a highlight of the whole thing. What was also interesting was we didn't encourage them. They came banging on our door trying to buy the license from us. We just couldn't be bothered with the whole thing. So when they turned up in person and said look you've ignored our letters but we want to produce these things in California and they wanted to give us money. So we couldn't really ignore it anymore. But they were really nice guys. Very American, and "Can do". So we ended up going out there to help them set it up. It was only for about two weeks or so. They had some people in Sacramento that were doing the moulding, and we had to go there to tell them what bits went where, and what thickness to use at various parts of the moulding. But they wanted to use a chopper gun to blow the fibreglass and resin at it and then just roll it out. But you can't do it that way because it finished up, say, an inch thick in some places, and too thin in others.

Q So did you hand lay the fibreglass?

Yes you had to do it that way, you just couldn't do it with a chopper gun. They thought it was going to be ever so easy because they had this mechanised way to do it, but in fact it needed to be done in a very labour consuming way. It just had to be done properly.

But they were good guys. And they subsequently bought more territory (at the point where we were liquidating the company), they came over again and offered the liquidator more money to buy the rights to do the car in the whole of the States instead of just California and six surrounding states (or whatever it was that they bought the first time).

The Guys were called Norman Rose and Cecil Robertson. They were in Oakland and had a large car repair business. They were doing this as a sideline because they were bored really with what they were doing. But they were really enthusiastic. A lot of their customers wanted fancy purple metal flake (the sort of stuff that we weren't really into as we had a more European taste).

Q Do you still have an example of the Nova today?

No I haven't had one since about 1975 I think.

Q Do you think the original car could be re-launched today as a viable business proposition?

I think the difficulty is that all that VW stuff is not really contemporary any more. And although you can buy these floor trays from Brazil or whatever I think it's really too outdated. There's been attempts to do mid engined versions with separate chassis and all that kind of stuff but it didn't really quite work

Q Do you have any idea how many Nova cars were made worldwide (I read somewhere that between 10 and 11 thousand had been made)?

I don't know Phill. We did 179, and then I kind of lost touch with it then.

By the way, the guy that was called Noel Redding or whatever he was called..... Neil Something?

Q Noel Mcmanus?

Noel McManus, yeah that's it. He was in Scotland when we did all this stuff with him. In a place south of Glasgow. We went to see him, we drove up in one of the cars from Lancashire and he had this sort of garage that was unbelievably untidy. He was a bit of a strange character, he spoke with a very educated English accent, but he was a kind of "Hippy" sort of person. Then he moved down to Queensbury in Yorkshire near to where we were. Whether or not that was Vic Elams place I'm not sure. But there was something when they were both doing it for a while. At that point I was in the situation where I was moving back to London to go to the Royal College Art because I had been sponsored by Rover to go there. So I wasn't really bothered about it anymore because it was someone else's thing by then.

But there was a situation around about that time where there were a few people who wanted to make moulds from it and there were legal contentions from various people who were making moulds from their own car. There was a guy in Swindon who did some sort of thing with a Cortina engine in the back. And (I don't know if it was Vic Elam that

started it) but anyway they all approached their lawyers to have a big battle about ownership of the design and they were sending writs to one another and stuff. But in fact it all came back to me. It found its way back to me because the lawyers said “look the person that owns the rights to this is Richard Oakes because he has got automatic copyright and he hasn’t actually assigned it to any of you. So really it’s back to him”. At that point I wasn’t really bothered. I didn’t really care whether they did it or not. I think it ended up with Vic Elam as the “last man standing sort of thing”.

Q Wasn’t there a problem with sourcing windscreens?

Oh yeah, I think maybe you’re right. I think triplex would only supply the screens to one person or something. That rings a bell that thing about screens.

Q Are you Still in contact with Phil Sayers?

No I haven’t been in contact with Phil Sayers for probably that length of time – since the mid seventies. I think there was a time about ten or fifteen years ago when he was working for a lady that did sculpturing. He was converting her sculptures into bronze or something like that (or maybe making them in fibreglass). I think he did that kind of work. But I’ve not spoken to him for about thirty years. I may have just spoken to him once in the eighties when he phoned me up and we had a little chat.

Before I moved to London in the sixties to work at Davrian (I did about a year there), Phil came to see me (because we were teenage buddies). And I said look Phil, I’m moving on from this job but you could do it you know. So I spoke to my boss and said I’m moving on but Phil here could do it, and he got the job. I moved on to Devon and he came and took my job at Davrian.

Q Presumably you weren’t already planning the Nova at that time?

No I wasn’t. It was only after a year in Devon that I went back to Phil and said I wanted to do this project. I told him this’ll be really good because it’s like a buggy but looks like a Ferrari and will be easy to build, so come on and do it with me. So that’s how it got going.

So then we approached John Willment who was very big in motorsport (he wasn't a boat builder, but he did have a shipyard). What he actually did was run a very big chain of Ford dealerships around London. His company built a lot of the GT 40s for Ford, the company was called JW Automotive.

Q Didn't you work at Ford at one point?

Yes I did but that was much later on, let me explain:

Davrian was '68-'69, and then I was in Devon while Phil was doing my job '69-'70. Then I came back from Devon and we did the Nova which was about '71-'72 when we were developing it. And '73-'74 when we were making and selling them. Then the Oil crises hit and we had to stop doing it. But we staggered on for about another 18 months (so that makes it about '75 and a half). Then we put the company into liquidation. Annie and I went to London in '76 where I did my masters degree at the Royal College of Art. I went to Ford after that. So '78 was when I was at Ford.

An interview with Sam Cobley

(Sam Cobley ran Nova Developments Ltd and Cobley Engineering from 1993 until 1997)

September 2006

Q1/ How did you come to obtain the rights to produce the Nova?

Originally I needed a new dashboard for my second Nova so I went about tracking down the moulds. Graham Slayfords company (Nova Kit Cars Ltd.) had gone bust and the official receiver told me of the whereabouts of the moulds. I visited a fibreglass subcontractor in Southend on Sea and tried to persuade them to make me a dashboard. They declined saying it would be too much trouble but I was told that they were given possession of the moulds by the receiver as they were owed money and all they wanted to do was to sell them. They went on to say they had produced hardly any Nova panels in two years and they were destined to be broken up unless they were sold. They were owed £5,000 by Grahams company and that was what they wanted. Now you have to bear in mind that the Elams were asking £750,000 for the business when they sold it. Jokingly I offered £1,500 cash and he said "when can you take the damn things away". They knew nothing of what is known as "the rights and title" so I contacted the official receiver. They quoted the following to me. "You cannot legally sell an item if it is not fit for the use for which it is intended". Hence, when they gave the subcontractors the moulds, the rights and title went with them automatically. So when I purchased the moulds for £1,500 the rights and title automatically came to me.

Q2/ How did you go about producing new moulds for the car? Were these produced from detailed drawings or were plugs for the new moulds sculpted and made up by trial and error until things looked "right"? (Please excuse my ignorance as I know nothing about the process of car styling though I have produced fibreglass mouldings (not of cars) of my own in the past and so understand the process of producing a mould from a mock up)?

I made the following new panels for the Nova.

Bonnet. This was the same as the mk2 but it actually fitted

Front under tray. This was as a mk2 but there was a proper flat panel to attach the number plate to

Roof. When I bought the moulds the car was being sold with the old mk1 roof. I altered the roof to move the screen two inches away from the drivers head and it also gave two inches more head room. The mk2 roof had two inches more headroom than the mk1 but the angle of the screen was the same. Our roof had the benefits of the mk2 but looked like the more attractive mk1. To make the new panels I just re-jigged the old panels with a lot of wood and filler. Then when it fitted perfectly took a mould from it.

Rear end. This was originally made as a "one off" for my good friend Gary but to do it properly I had to make a mould. I was so pleased with the result it became the mk3 rear end.

Q3/ Looking back, was it a good experience running Nova Developments Ltd? What were the highlights, and what were the lows?

I had loved the Nova since I was 14 years old and desperately wanted one for years. I built my first one in 1983 my second one in 1987. When I was driving back from Southend on Sea having just bought the moulds I shouted at the top of my voice "I now own the Nova". At that time I had no real plans to go into production but there was a definite demand for spares and at the Bristol kit car show I was tracked down by someone wanting to order a kit. It was like a snowball rolling down a hill. Within weeks word was out and the magazines were calling me asking for future plans and wanting to come down and meet me. There was a euphoric feeling at that time, I was actually living my dream and at any time I was afraid that I may wake up.

After Three years of production the work had taken its toll and my marriage was at an end. The Nova business was actually a paying hobby and I still had a full time day job. The workload was killing me. Nova Developments ltd as a company was set up by my wife and I, and as part of the divorce she insisted that the company be dissolved.

Hence for about 18 months afterwards I traded as Cobley engineering. At about this time the industry changes and the SVA test was looming. I checked the car and at that time I felt that too much investment was needed to get the car through so I decided to sell the business.

Q4/ What could you have done better with the benefit of hindsight?

I actually feel that at that time our show appearances were as good as any other manufacturer and we had a good market presence. I did however spend too much time on trying to get it perfect. Other manufacturers were producing rubbish and selling it just a little bit cheaper. I could have made more money if I had followed their lead.

Q5/ If Nova Developments Ltd. had continued, how would the Nova have developed under your control?

We were working on a space frame chassis which used mk3 escort running gear mid mounted. We displayed the chassis at the Stoneleigh show and sold two to customers. They were sold on the proviso that they were not perfect and further work was needed. The customers were so desperate for them that they took them before they were ready.

Even ten years ago I had ideas for a lightweight carbon fibre version with a small three cylinder turbocharged diesel engine which would return over 75mpg I just had a feeling that in the future there would be a call for very fuel efficient cars. On this point you should contact my friend Adrian also a Nova owner and get him to tell you about his research into the electric powered Nova. It will make you think "conspiracy" by the oil companies.

Q6/ Why did you decide to sell up and do you ever regret selling on the rights to produce the Nova?

As stated earlier a lack of customers and a messy divorce watered down my enthusiasm and I decided that I needed to relax more.

Q7/ Do you still have an example of the Nova today?

I don't have a Nova but I often trawl the web for information and if one came up at the right price locally I may have it as a Sunday driver.

It would have to be a mk1 with all original panels and a Southampton body, in lime green

Q8/ What happened to the Nova moulds, jigs and drawings after you sold it on?

By the time I sold the Nova we had all of our work done by sub contractors. When we sold the business to the new owner Shashi Vyas he kept the moulds and new space frame chassis production where it was, here in Cornwall.

Q9/ Do you think the original car could be re-launched today as a viable business proposition?

Honestly no. Today's young men no longer yearn for a car that looks like a Lambo that they can tinker with on a Sunday morning. They want rice rockets with fluorescent lights underneath and silly wings on the back. If you had a farm with outbuildings and the storage of the moulds did not cost you anything then you may sell a few kits and some spares but it would be nothing more than a hobby. In its current form it is no longer viable as a business.

Q10/ Do you have any idea how many Nova cars were made worldwide (I read somewhere that between 10 and 11 thousand had been made)?

I think that the numbers are over inflated. Richard Oakes sold about 180 I think in this country. Graham apparently did not sell any, and I sold 15 full kits. I don't know about the Elams.

Q11/ Tell me a secret about the Nova that no one else knows?

It was to be used in the Film Judge Dredd with Sly Stallone but I was not able to produce the cars quickly enough. So they" went another way"(as they put it).

The bushes in the roof hinges are the clutch pedal bushes from a Peugeot 305.

As of two years ago I think I still know the location of the moulds.

Shashi I think still has a website for Aerotech Nova and the last I heard, he claims he was still in production.

I never actually spoke to Graham (Slayford) but when we were in full swing he tried to sue me for use of the name and claimed the moulds were still his. We wrote to his solicitor and once we quoted the official receiver we never heard from him again

I do have some pictures of the moulds and production etc from that time. They are not digital but if they are to appear in your book I will sort you some out.

Sam Cobley – September 2006.

An interview with Mike McBride who runs “Solid Sterling”

Q1/ How did you come to obtain the rights to produce the Sterling in America (who did you buy it from and what year)?

I purchased the moulds from Redhead Roadsters in Dec. '95. That company was a one-man Hobby type business, the same as mine. These moulds were purchased by him in Canada and brought down to Waitsburg Washington where he built kits and cars on a part-time basis.

I contacted the original owners of California Component Cars in San Lorenzo California to find out if I needed to buy the rights to build the Sterling from them or any subsequent owners of their moulds, and they told me that the car had become public domain, and that no one needed the rights to build them. They had not been produced actively for many years, and no one seemed to care who built them by the time I started.

Q2/ Did you introduce any styling changes to the car - If so what were these?

I did introduce some changes to the car, while trying to stay true to Richard Oakes' original design concept. Some of the changes were made to make the car easier to build or work on, and some were because of original parts becoming obsolete or hard to find.

The most major change was a targa top. Redhead Roadsters had designed a simple targa with a roof section that came off with no obstructions between the windshield and the rear of the top. If the windows were removed it made the car an open top roadster. This top, however, had no inner liner, and no rain channels, and could not be sealed to keep from leaking in the rain. I could not live with that, so I started from scratch with an original top, cut out the roof, and moulded the cut edges so there was a drainage channel for water to go through and run down a tube through the windshield posts to drain out at the lower edge of the top. The removable roof panel was made with a rain shield extension over the top edges of the windows so there was nowhere for water to get past the window weather-strips. I also made

a mould for an inner liner for the top so it was finished nicely on the inside. When the inner and outer shells were laid up, I used carbon fibre in the windshield posts and front apron area on both sides so the weight of the windshield wouldn't put stress cracks at the base of the posts. It is very strong and rigid, and has held up well so far with no bracing or supports for the windshield.

I redesigned the tail section, as the old Triumph taillights are obsolete. I left the rear corners and wheel well part the same, but in the taillight area there is an inset flat panel all the way across which will work for any automotive taillight that will mount properly on or in a flat surface. I used Datsun 280ZX lights turned upside down, as I thought they looked like they belonged on the Sterling, and between them is a space that is perfect for a license plate and light.

I also redesigned the engine cover lid to extend to both "sail" sides to cover and allow access for dual carburetors on a VW engine.

I used vacuum fluorescent digital gauges from Dakota Digital in the original straight style dash that CCC used after they quit using the "pod" style 3 piece dash.

I don't bolt the dash to the body, and I always recommend to other builders and restorers the technique I use, which is to use two common house door hinges at the front corners of the dash so it can be lifted up to have easy access to the wiring. Of course, one has to build a support to bolt the steering column to so it isn't attached to the dash.

Q3/ Looking back, was it a good experience running Solid Sterling?
What were the highlights, and what were the lows?

Running Solid Sterling was a great adventure, but had I known how demanding of my time it would be, I don't know if I would have done it.

I was trying to run a business with very little financial means to start with, and had only spare time left from my full-time job in which to work. When I look back on it, I should have not made it through the first year, let alone eleven!! Even with all the stress of deadlines, low finances, inability to find certain parts, etc., I am still glad I could be

part of the Sterling legacy. I feel like a very insignificant chapter in the history of the most beautiful sports car ever built, but do feel proud that I was able to keep the car in the public eye and help keep interest in it alive and kicking.

The low points in my experience with this business reared their ugly heads occasionally, like the time I ordered a bunch of custom made windshields from a factory who said they could make them perfectly for me. The first 3 samples they sent were the wrong size or the wrong curvature and couldn't be used for anything. When they finally got it right, they shipped five to me in an improperly designed crate and all five were broken. They and the freight company both denied responsibility, and I ended up paying the price. Later they went out of business and I had no source of windshields at all. I was getting a little panicked when I finally found a factory to make them for me, but they would not make any unless I ordered their minimum number, which was way beyond my financial means at the time. I continued to call every glass company I could find, and finally found my glass guardian angel! He owns a very large glass company, and agreed that if I would buy a minimum of five windshields on my first order, he would contact the factory and purchase their minimum run of windshields and stock them in his warehouse for me to exclusively purchase whenever I needed one. Had it not been for his generosity to a tiny little company, Solid Sterling probably would have folded back then. What good is a car if you can't buy a windshield for it?

Another low point showed up with the construction of my first car. The moulds were a lot worse than what I thought they were when I got them. Many were so shrunken or warped that I could barely use the parts that came out of them. I had to either repair or totally replace most of the moulds before I could make anything to sell. Others had to be redesigned or repaired later on.

Along with those, and not just a few other problems, came the good side of being "Mr. Solid Sterling" over the years. The best part of it all was the privilege of meeting many hundreds of really great Sterling/Nova people around the globe. So many of them contacted me over the years that it is impossible to remember more than a small percentage of them personally, but I value the conversations with all of them highly. Many people suggested new ideas to incorporate in the

cars, some of which were really helpful. Others just wanted to visit and ask questions.

We managed to find the time and money to take our car to the Knotts Berry Farm show one year, and met a lot of Sterling fans there. We also attended the Northern California Kit Car Club "Bash by the Bay" in San Leandro CA. We met some other Sterling owners there with whom we stayed for a couple of days after the show, and went to a drive-in movie with all our Sterlings in a row. It was great fun!

I am an honorary member of the National Sterling Owners Association which is growing steadily as more Sterling/Nova owners are finding out about it. I have hoped for years that someone with the time and knowledge to do so would start a Sterling organization and provide a single main meeting point for all enthusiasts to meet and communicate with each other, and now it has happened.

Had I not met one particular Sterling owner, I would most likely not even be using a computer these days. He needed some parts, and asked me to email him the information on them. I said "Well, that would be difficult since I've never owned or used a computer!" He told me I just HAD to have a computer to be in business, and explained that his company buys new computers about once every year or two, and always have extras to get rid of. He said he'd ship me one. I figured that would never happen, but to my astonishment, a big box showed up on my doorstep a week later with a totally internet ready computer system. I wore that one out, and have gone through two more since then, but I'll always be grateful to him for his generosity, and for getting me to join the twenty first century.

Q4/ What could you have done better with the benefit of hindsight?

Had I known then what I know now, I never would have gotten into any business, let alone the kit car business. I am NOT a businessman by any stretch of the imagination. I'm just a guy who loved Sterlings and thought it would be great to build them for a living. I've learned a lot over the years through the school of hard knocks, and have been able to provide hundreds of people with kits, parts, or turnkeys, but it has been very difficult at times.

With the benefit of hindsight I would have not started without sufficient finances. The key to success in this business is to have the kits in stock ready to ship when you get an order. I couldn't do that because of lack of money, lack of time, or a combination of both. I would have found fibreglass fabricators to contract all the kit body parts rather than trying to keep up with orders doing all my own lay-up work. I would have hired someone with business savy to handle the phone calls, paperwork, order shipping, and computer work so I could concentrate on gathering parts and assembling cars and kits.

Q5/ Why have you decided cease production of the Sterling?

I have decided to quit producing the Sterling for several reasons.

I am 59 years old and have about 25 projects I'd like to be able to finish before I'm too old and crippled to do them. I have several big antique trucks I want to restore or build into car haulers. I have an old hot rod body and frame I'd like to build into a show rod. I have a 20 foot fibreglass antique boat I want to fix up so my wife and I can cruise the river we look at from our back deck daily. That's just a few of my future projects, and there is simply no room in there to continue building Sterlings.

I do plan to continue providing most of the non-fibreglass parts for the Sterling as far into the future as I'm able. These will be parts I don't have to manufacture such as the windshields, side windows, top lift hydraulic systems, etc. These won't take a lot of my time to provide to people, as I can just pick up the phone and have the parts shipped directly to the customers.

Q6/ Do you think the car could be re-launched today as a viable business proposition?

I really believe that if the right person with enough money and business knowledge were to get into the Sterling business, that person could do very well, but it would take a year or two to build trust among the kit car community.

People have been stung by crooked kit car businesses over the years, and it takes time to build a reputation of honesty and integrity. I have worked very hard to build that kind of reputation and I think, for the most part, I have succeeded.

Q7/ Do you have any idea how many Nova/Sterling cars were made worldwide (I read somewhere that between 10 and 11 thousand had been made) - how many did your company produce?

I really don't have any idea how many Sterling/Novas have been built worldwide. I don't even know how many in the USA.

I think 10 or 11 thousand may be a stretch. I heard that CCC in California, one of the most prolific companies to ever build the Sterling, built about 1500, but I don't have anything to substantiate that number. It could be a much higher number, but I doubt that they made fewer than 1500. That figure could even be a yearly production figure, I just don't know.

My company is statistically not even on the map as far as production numbers go! As I said, it has been a hobby business and not a production factory. I built three turnkey cars, each averaging about 1 1/2 years to 3 years to build, and probably about 4 complete kits were shipped to customers.

I have probably, however, sent enough individual parts all over the place to build 3 dozen more cars, minus the main body.

Q8/ Tell me a secret about the Sterling that no one else knows?

I know there are other people who have discovered some of the things I have, but not all of my discoveries are widely known or publicized. I have to humbly apologise to Richard Oakes for telling you about a couple of things. I am in no way criticising his skill at designing this car, and the facts I am going to tell you may not have even been his responsibility. It could have been someone else involved in the manufacture of the moulds who goofed, such as the guys at CCC when they made their moulds. Well, enough apology already!!

OK, one thing is the pockets where the gas shocks or hydraulic cylinders mount for the top lift don't measure the same on both sides. One is shorter front to back than the other.

Another fact, which I'm sure most Sterling kit builders discovered when they added the wheels and tires, is that the body sits off centre in the rear by about 1/2 or 3/4 inch

The only other "secret" I can think of was told to me by a Sterling owner who installed a Mazda RX7 rotary engine in his car. He said that with no air dams, spoilers, or other body mods, the Sterling body becomes a lifting airfoil at about 135 miles per hour! I certainly have never tested his statement myself, but he assured me he had, and managed through driving skill or pure blind luck, to slow his car enough, before it was too late, to not go airborne.

Mike McBride - September 2006

Acknowledgements

I wish to express my thanks to the many people who helped me to produce this book.

In particular I would like to thank the following:

Steve Cook (UK)
Richard Oakes (UK)
Sam Cobley (UK)
Greg Hampton (USA)
Steve Silverstein (USA)
Rick Milne (USA)
Farzad Sharif (USA)
The Triford Motor Company (UK)
Paul Hawkins (USA)
I. R. L Sutherland - Cover photography (UK)
Adrian Heath (UK)
Mike McBride (USA)
Phillip Karam (Canada)
Bertone (Italy)
David Aliberti (USA)
Tom & Marilyn Ross (USA)

Resources

Websites

Nova-International.net

Novakitcars.co.uk

Novakitcars.freeservers.com

Nova-portal.de (German Site)

Sterlingkitcar.com

Sterlingcentral.com

Nationalsterling.org

Eurekacarclub.com.au

Eurekacarclub.com

Index

A

Acrington · 12, 22, 46
Adrian Heath · 43, 117
Aerotec Nova · 21, 22
air intakes · 10, 15, 24, 27, 35, 36, 95
Al Hildenbrand · 25
Allan Purvis · 35
Automotive Design and Development Ltd
· 24, 46

B

Batman · 18
Bermuda · 17, 18, 96
Bertone Testudo · 10
body plug · 14
Body Shell · 69
Body shells · 6
Bond bug · 11
Bremen Manufacturing · 25
Bumper moulding · 15

C

Cabriolet · 16
California Component Cars · 23, 29, 34,
110
Cecil Robertson · 23, 101
Centaur · 7
Chassis · 17, 53
Chevrolet Corvettes · 10
Chevrolet Nova · 23
Cimbria · 1, 26, 27, 34, 45, 95, 100
Cobley Engineering · 21, 22, 105
Colleen Long · 37
Condorman · 15
Crestwick Ltd · 14

D

Davrian · 9, 11, 103, 104

Defi · 1, 39, 45
Demo cars · 14
Denis Adams · 7
Disney · 15
Don Law · 15, 45
Dragonfly · 42, 43

E

Eagle · 1, 27, 28, 34, 39, 45
ego · 9
Elam · 103
Engine · 73, 75, 84
Eureka · 1, 35, 36, 37, 38, 45, 95

F

fibre glass · 13
fibreglass · 12, 14, 19, 21, 25, 26, 69, 76,
82, 86, 91, 93, 101, 103, 105
Floor Pan · 5, 53, 56
Ford GT40 · 9, 10
Ford motor company · 11
Freedom Machine · 37
Front Axle · 53, 58
Fuel Tank · 68

G

Gelcoat · 99
Gerry and Sylvia Anderson · 15
Gerry Anderson · 15
Graham Slayford · 18, 22, 105
Gryff · 1, 39, 45

H

Heating · 85
higher roof line · 15, 25
Hydraulic · 85

I

influences in future car styling · 10

J

jigs · 13, 108
Joe Palumbo · 26, 100
John Willment · 11, 98, 104
JW Automotive · 11, 104

K

Kit Car · 1, 2, 9, 21, 53

L

Lamborghini Countach · 18
Lamborghini Miura · 9, 10
Lamborghini Urraco · 46
Ledl · 1, 39, 45
Lowering · 54, 75

M

Mako Shark design exercise · 10
Martin Brown · 21
Mike McBride · 30, 34
Mirfield · 15, 16, 18, 22, 82
moulds · 11, 13, 14, 15, 19, 20, 25, 26,
27, 28, 99, 102, 105, 106, 108, 109
Moulds · 19, 22, 23, 30

N

Neria · 27, 34, 45
Newquay, Cornwall · 19
Noel/Neil – Mcmanus/Reading · 13, 102
Norman Rose · 23, 101
Nova Cars · 13, 15, 22
Nova demonstrator · 16
Nova Developments Ltd · 19, 105, 106,
107
Nova Kit Cars Ltd · 18, 19, 105
Nova MK 2 · 46
Nova Sports Cars · 8, 15, 22, 91
Nova SSD · 14

O

Oil crisis · 12
opening canopy · 10, 11, 26

P

patterns · 11, 99
Phil Sayers · 11, 12, 22, 23, 98, 99, 100,
103, 104
primer · 14, 15
Probe · 6, 93
Probe 2001 · *See* Dennis Adams
prototype Nova · 11
Pulsar · 7
Puma · 1, 39, 40, 45
Purvis Eureka · 1, 35, 36, 37, 38, 45, 95

Q

Queensbury · 13, 102

R

Reconditioning · 53
Richard Oakes · 5, 7, 9, 12, 13, 22, 23, 46,
47, 48, 92, 95, 96, 97, 98, 103, 108,
110, 115, 117
rights and title · 19, 105

S

Saab · 94
Sam Copley · 5, 19, 20, 21, 22, 45, 105,
109, 117
Scorpion · 1, 39, 45
Sebring · 1, 25, 26, 27, 34, 45, 95, 100
Shashi Dvyas · 21
Sovran · 1, 15, 29, 30, 34, 45, 95
Speedo · 79
Stanley Kubrick · 6
Sterling · 1, 5, 23, 24, 25, 26, 27, 29, 30,
31, 32, 34, 45, 95, 101, 110, 111, 112,
113, 114, 115, 116
Steve Driver · 14, 45
Super Cars · 9
SVA · 107

T

Tarantula · 1, 39, 40, 45, 46
Targa Top · 32
TFS Ltd · 18, 22
The Caledonian Probe Motor company · 6
Tim Dutton Wooley · 27
Totem · 1, 39
Tramp Beach Buggy · 9
Transaxle · 53, 60, 62
Transplas · 18

U

Under tray · 19

V

Vanguard Mouldings · 19
Variant · 73, 74
Vic elam · 13, 15, 16, 18, 21, 22, 96, 100,
102
VW Beetle · 6, 10, 16, 21, 28, 36, 50, 51,
54, 62, 68, 73, 75, 77, 79, 82, 84, 86,
87

W

Western Laminates · 9
Wheels · 74, 96
windscreens · 15, 103

